

Touch'N Pay Technical Manual V2



READING THE MANUAL

This manual includes chapters on safety instructions, use, installation, and problem resolution procedures. Reading this manual carefully before using your product will help you use and maintain it correctly.

BEFORE CONTACTING YOUR AFTER-SALES SERVICE

The section on problem resolution procedures (FAQ) will help you solve some common problems yourself without needing to contact technical support.

After-sales service contact details can be found at the end of the page (FAQ).

Please always have the device's serial number on hand before contacting after-sales service.

General warning

This product is designed for professional indoor use only, in accordance with the descriptions and safety instructions stated in this manual. For your safety, please follow all safety instructions.

This product must:

- Be protected from rain.
- Be used only in combination with original spare parts, accessories, or peripheral devices.
- Operate only with the type of power supply indicated on the product nameplate.

This product must not be installed under extreme conditions of humidity, dust or vibration.

LM CONTROL declines all responsibility in the event of damage caused by non-compliant or incorrect use of the product. Any unauthorized modification intended to add new features or to connect this product to external devices may affect the device certification and therefore its safety. For any questions about adding features, we invite you to contact your LM Control sales representative.

All cleaning and maintenance procedures are described on the support site: <https://support.lmcontrol.com/>

If it is kept in good operating condition and correctly installed, the device does not present any type of hazard to the user.

Lethal hazard warning



The product uses electrical equipment that must be connected to an electrical network that complies with the nameplate located inside the product.

Before installation, it is necessary to ensure the quality and compliance with the applicable standards in force for the operation and compliance of your electrical switchboard.

WARNING: Any error may cause damage to the product and overturn the warranty.

- Any connection or work must be carried out by a qualified and authorized technician. Do not use this device when it is faulty. In the event of a malfunction, call a qualified technician or LM Control via Hotline contact.
- Never open the product with wet hands.
- Never touch the power plug with wet hands.
- Never unplug the machine by pulling on the power cord.
- Do not remove protective components.
- Never wash the device by spraying it or pouring water over it. Risk of electric shock.
- Never put liquid inside or outside the device. Never place liquid on top of the product.
- Before each use, check that the cable or mains plug is not damaged. Have any damaged power cable replaced immediately by a qualified and authorized technician.
- Never install the product in an ATEX area or near chemicals. Switch off the product at the electrical switchboard before any installation, maintenance, or cleaning procedure.

Injury hazard warning

The product contains heavy equipment that, if handled incorrectly, may create risks of injury, or even crashing.

- When handling the product, wear PPE such as protective gloves and safety shoes, and follow proper handling and posture rules.
- Never move or carry it alone.
- Before transporting the product, make sure that no loose parts are inside, that the door is properly locked, and that the key has been removed.
- Do not lean on the door when the product is open, as this may cause the fasteners to break.
- Do not insert anything into the fan.
- Be careful when handling any moving part.

End-of-life equipment recycling

The product is WEEE (professional Waste Electrical and Electronic Equipment) which, at end of life:

- Must not be disposed of in a bin like regular waste.
- Must be collected and disposed of through a dedicated recycling stream.



LM CONTROL is a member of **ecosystem**, which coordinates the collection, decontamination and recycling of our used equipment, in accordance with the highest environmental requirements. **ecosystem** is an eco-organization approved by the public authorities for the professional WEEE recycling stream.



Glossary

INSTALLER	The person who receives unpacks, installs, connects and configures the operator's payment kiosk.
OPERATOR	The person who owns the kiosk at their point of sale. The operator provides daily maintenance of the payment kiosk.
SERIAL NO.	Each payment kiosk has a non-modifiable serial number ensuring product traceability.

Table of contents

1. GENERAL DESCRIPTION	6
1.1. FUNCTIONALITY	6
1.2. BOX CONTENTS	6
1.3. DEVICE IDENTIFICATION	6
1.4. EXTERNAL & INTERNAL DESIGN – TOUCH'N PAY KIOSK	7
1.5. TECHNICAL SPECIFICATIONS	14
2. TECHNICAL INSTALLATION MANUAL	15
2.1. NETWORK CONFIGURATION PREREQUISITES GUIDE	15
2.2. UPON RECEIPT	16
2.3. TECHNICAL INSTALLATION	16
3. PRODUCT CONFIGURATION	22
3.1. DIAGRAM OF THE SETTINGS MENUS	23
3.2. MAIN MENU	24
3.3. SELECTIONS	24
3.3.1. <i>Add / Edit a selection</i>	25
3.3.2. <i>Description</i>	26
3.3.3. <i>Price</i>	27
3.3.4. <i>Product suggestions</i>	28
3.3.5. <i>Dry contact mode</i>	29
3.4. SCREEN ROTATION	32
3.5. CHANGE THE PASSWORD	32
3.6. PAYMENT METHODS	33
3.6.1. <i>MDB</i>	33
3.6.2. <i>Free codes</i>	36
3.7. FINANCIAL AUDIT	36
3.8. ADVANCED SETTINGS	37
3.8.1. <i>System</i>	37
3.8.2. <i>Network</i>	38
3.8.3. <i>Automation</i>	38
3.8.4. <i>Interface</i>	39
3.8.5. <i>Display</i>	39
3.8.6. <i>Information</i>	40
3.9. SCHEDULER	41
3.10. DIAGNOSTICS	44
4. USER MANUAL	45
4.1. MENU OVERVIEW	45
4.2. DRYING MODE (MULTIPLE SALE)	46
4.3. PAYMENT	47
4.4. PAYMENT ACCEPTED / DECLINED	48
4.5. USING A FREE CODE	49
5. MAINTENANCE	50
5.1. CLEANING AND MAINTENANCE	50
5.2. COIN ACCEPTOR UNIT CLEANING	50
5.3. BANKNOTE READER CLEANING	51
5.4. CARD DISPENSER CLEANING	51

6. FAQ-FREQUENTLY ASKED QUESTIONS.....	52
7. ANNEXES.....	54
7.1. CONNECTING THE IEC CONNECTOR.....	54
7.2. TNP-SL KIOSK – WALL MOUNTED	57
7.3. TNP-L0 KIOSK – WALL MOUNTED	58
7.4. TNP-L1 KIOSK – WALL-INSERTED	59
7.5. TNP-M0 KIOSK – WALL MOUNTED.....	60
7.6. TNP-M1 KIOSK – WALL-INSERTED	61
7.7. TNP-P0 KIOSK – WALL MOUNTED.....	62
7.8. TNP-P1 KIOSK – WALL-INSERTED	63

1. General description

1.1. Functionality

The TOUCH'N PAY range is available in several models, all equipped with a 7 to 22" touchscreen and an embedded computer optionally equipped with coin acceptor, banknote reader and card payment systems. All these parts are sold and maintained by LM Control.

1.2. Box contents

- 1 payment kiosk
- 1 power cord
- 1 power connector
- 1 or 2 RJ45 cables (depending on model)
- 2 keys

1.3. Device identification

The device is identified by a nameplate located inside the terminal. The warranty is linked to the serial number.

The information on this nameplate will be requested in case of a support request.



1.4. External & Internal Design – Touch'N Pay Kiosk

Model: TNP-SL

External presentation :

- (1) Case
- (2) Door
- (3) Bank terminal
- (4) Touch screen
- (5) Lock
- (6) Antenna

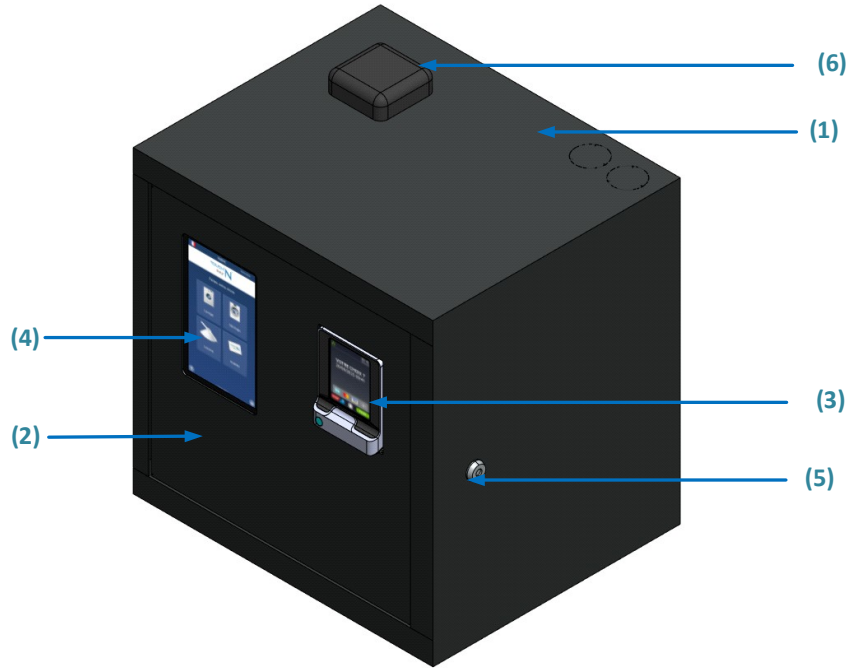

Internal presentation :

- (7) Embedded computer
- (8) Fan

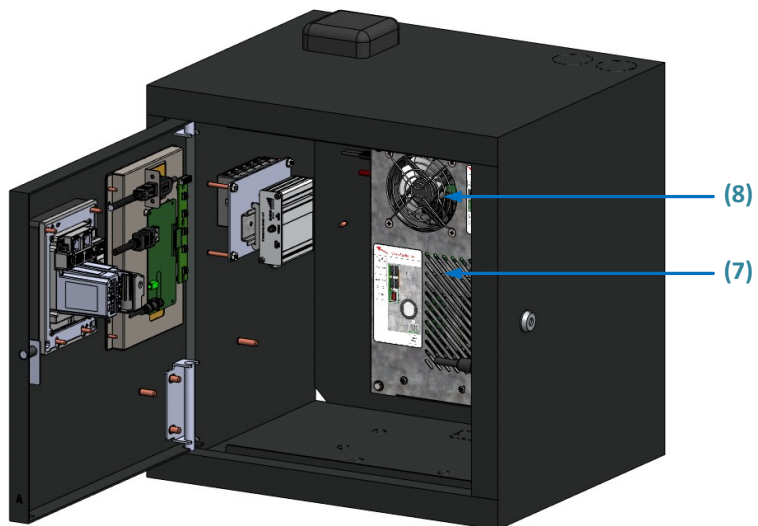

Model: TNP-M0

External presentation :

- (1) Case
- (2) Change return button
- (3) Cash reader
- (4) Touch screen
- (5) Bank terminal
- (6) Money back
- (7) Antenna
- (8) Door

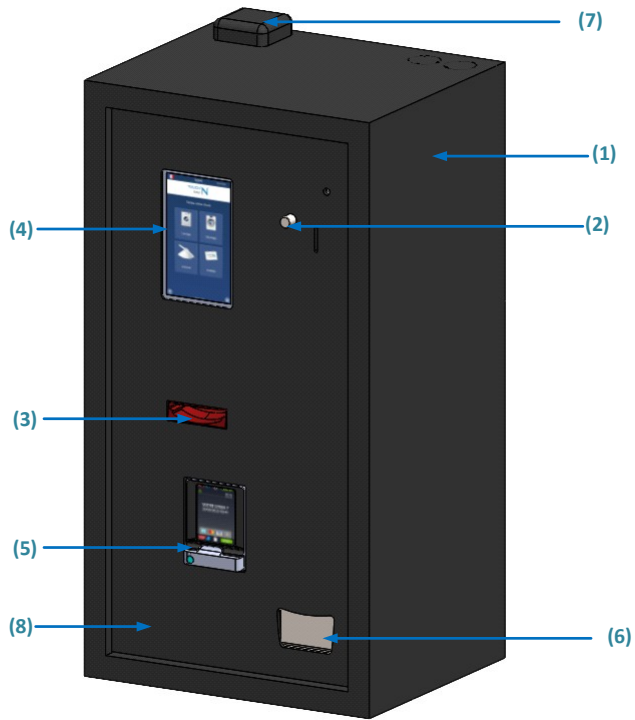

Internal presentation :

- (9) Fan
- (10) Power button
- (11) Embedded computer
- (12) Cash box
- (13) Money box

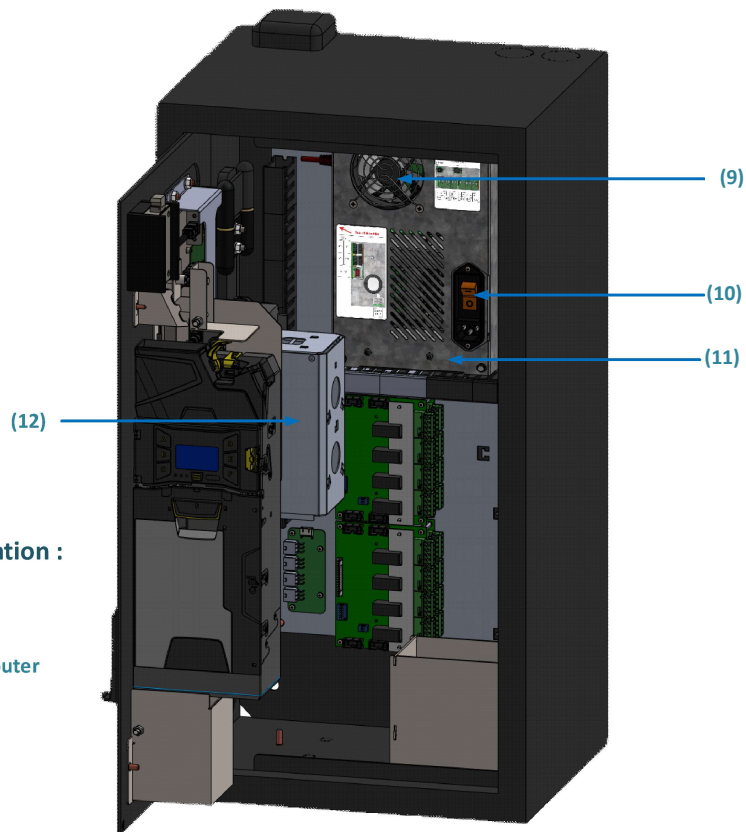

Model: TNP-M1

External presentation :

- (1) Case
- (2) Bouton Money back
- (3) Door
- (4) Cash reader
- (5) Money back
- (6) Touch screen
- (7) Bank terminal
- (8) Antenna

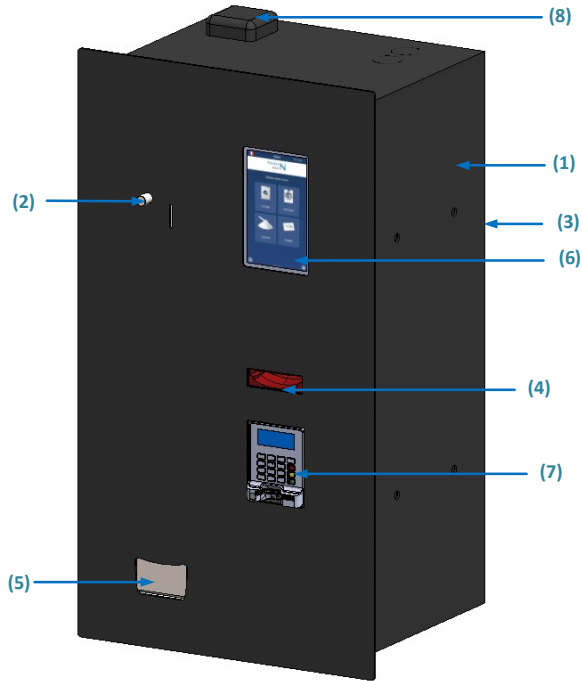

Internal presentation :

- (9) Power button
- (10) Embedded computer
- (11) Fan
- (12) Cash box
- (13) Money box

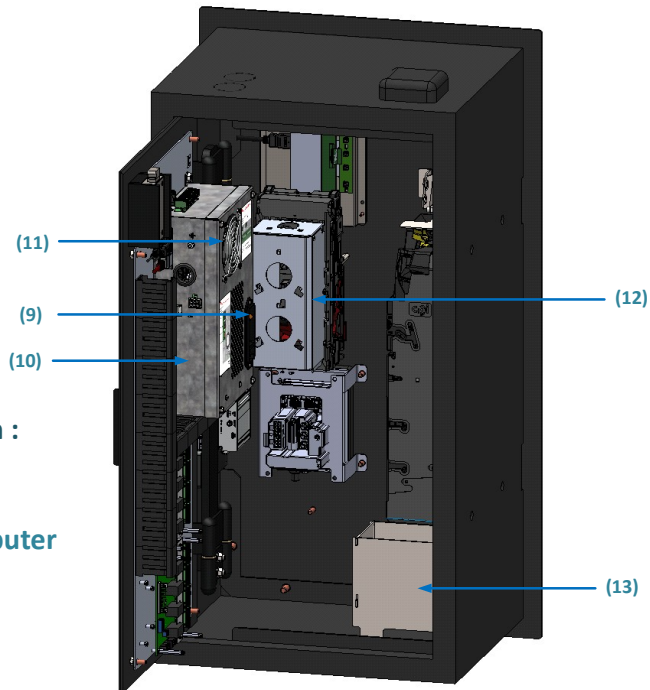

L0

Model: TNP-L0

External presentation :

- (1) Case
- (2) Change return button
- (3) Door
- (4) Cash reader
- (5) Money back
- (6) Touch screen
- (7) Bank terminal
- (8) Card distributor
- (9) Antenna

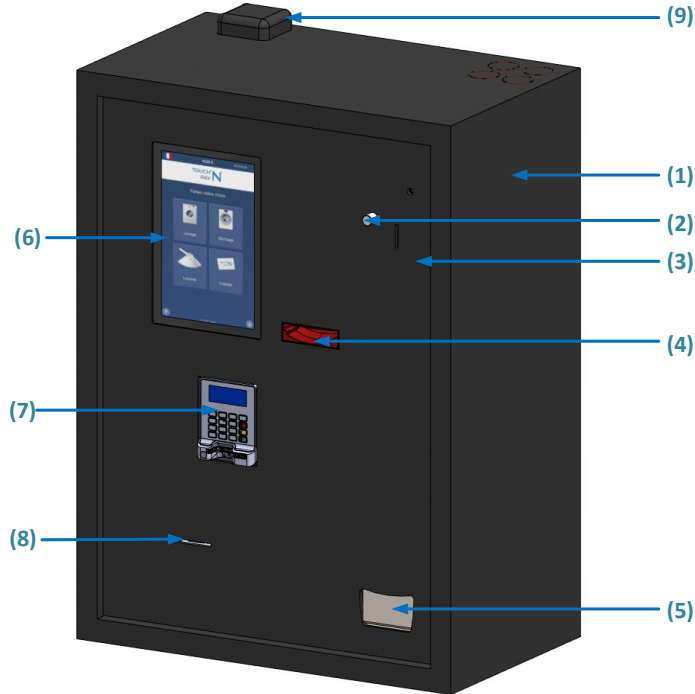

Internal presentation :

- (9) Power button
- (10) Fan
- (11) Embedded computer
- (12) Cash box
- (13) Money box

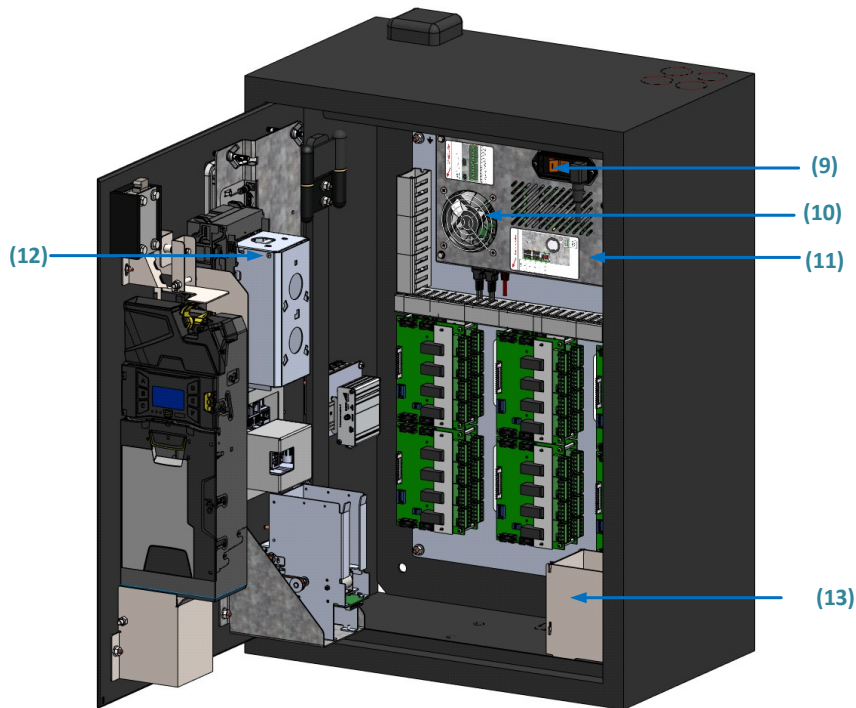

Model: TNP-L1

External presentation :

- (1) Case
- (2) Change return button
- (3) Cash reader
- (4) Touch screen
- (5) Bank terminal
- (6) Card distributor
- (7) Money back
- (8) Antenna



Internal presentation :

- (9) Power button
- (10) Embedded computer
- (11) Fan
- (12) Cash box
- (13) Money box

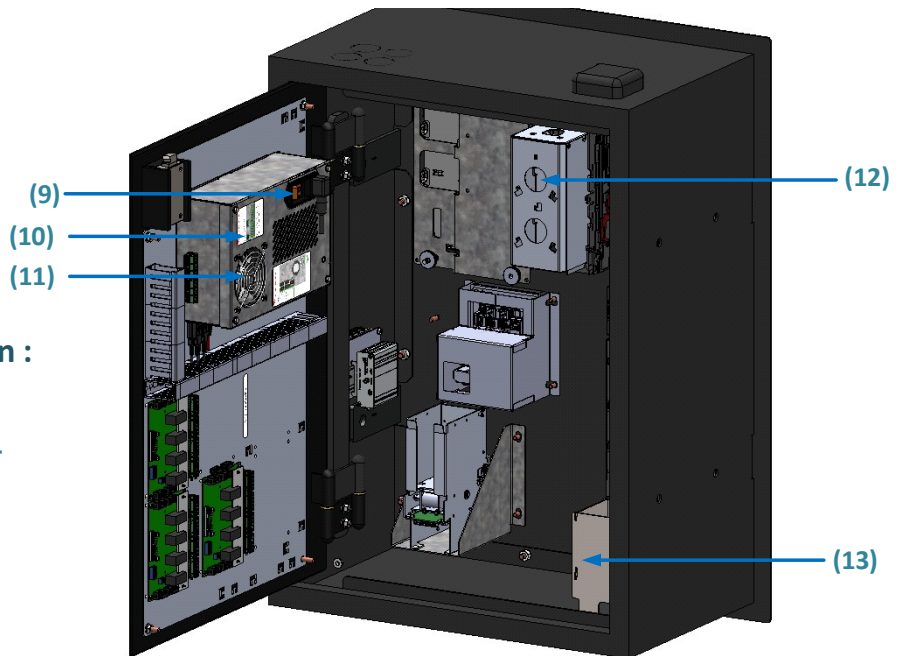

Model: TNP-P1

External presentation :

- (1) Case
- (2) Change return button
- (3) Door
- (4) Cash reader
- (5) Money back
- (6) Touch screen
- (7) Bank terminal
- (8) Antenna

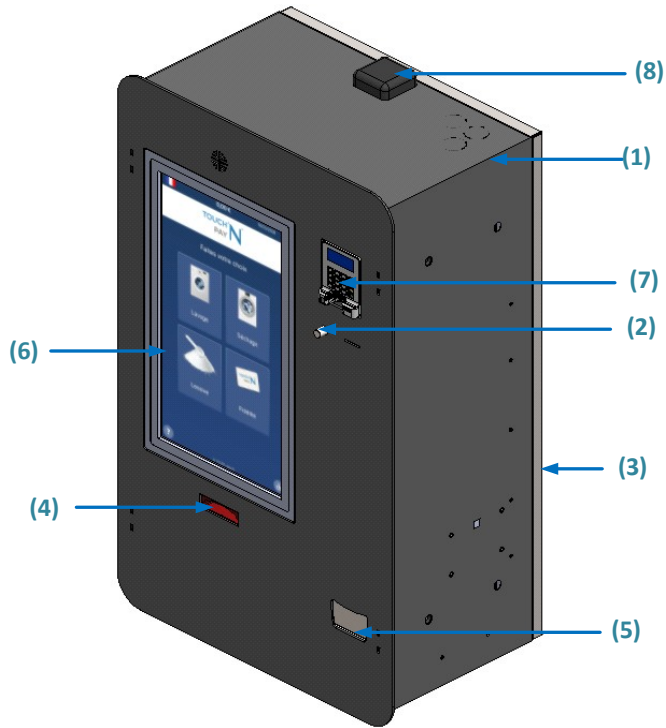

Internal presentation :

- (9) Power button
- (10) Embedded computer
- (11) Fan
- (12) Cash box
- (13) Money box

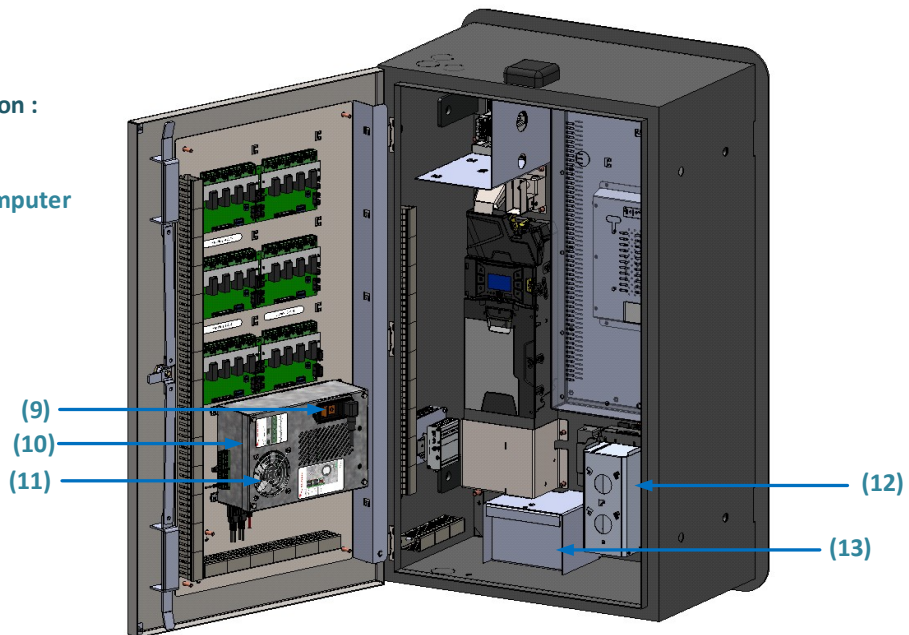

Model: TNP-PO

External presentation :

- (1) Case
- (2) Door
- (3) Touch screen
- (4) Bank terminal
- (5) Antenna

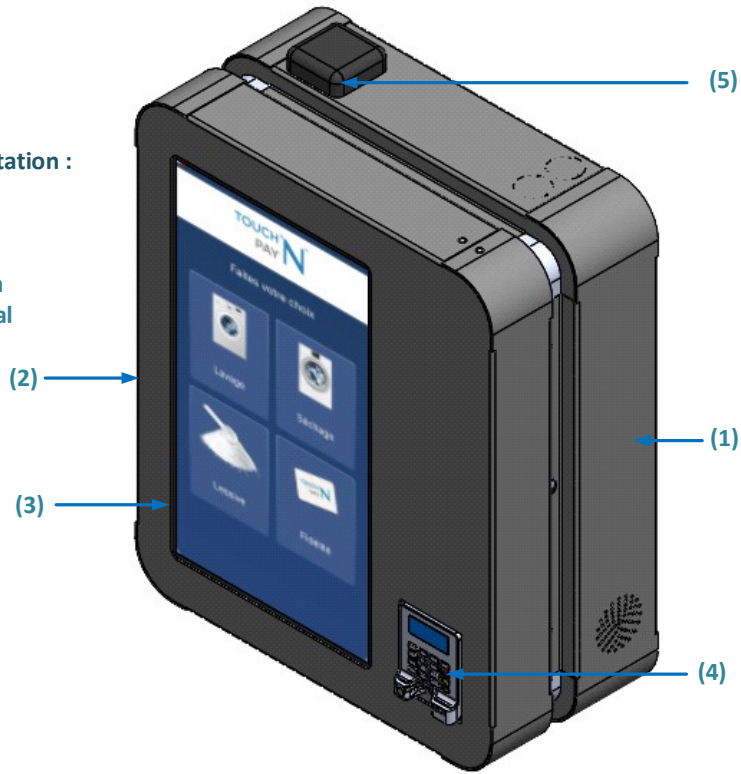

Internal presentation :

- (6) Fan
- (7) Embedded computer
- (8) Power button

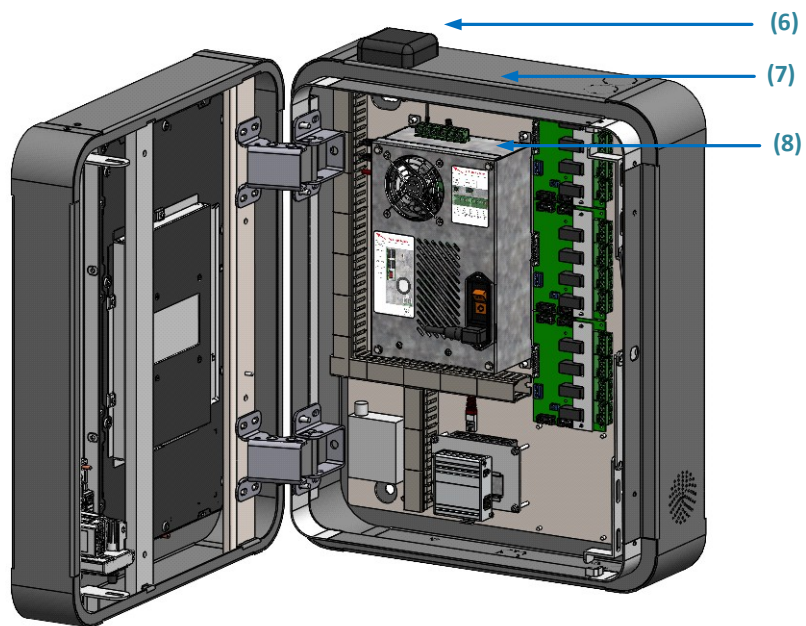

1.5. Technical Specifications

Terminal	Range L	Range M	Range S
Maximum number of controlled machines	Standard 12 – max 32	8	8
Ergonomics	Wall Mounted or Wall-inserted	Wall Mounted or Wall-inserted	Wall Mounted
Dimensions W × H × D (mm)	550 × 750 × 330	400 × 750 × 330	400 × 400 × 330
Door / Box sheet thickness (mm)	6 / 3	6 / 3	6 / 3
Weight (kg)	74 Wall Mounted / 81 Wall-inserted	50 Wall Mounted/ 55 Wall-inserted	20
Embedded computer	Yes	Yes	Yes
Remote software update	Yes	Yes	Yes
Touchscreen			
Size	10.1 inches	7 inches	7 inches
Resolution	1280 × 800 – 60 Hz	1280 × 800 – 60 Hz	1280 × 800 – 60 Hz
Impact rating	IK-07	IK-07	IK-07
Protection	—	Flexible hybrid glass film	—
Options			
Card dispenser	Yes	No	No
Loyalty card	Yes	Yes	Yes
Remote management	Yes	Yes	Yes
Paperless invoice	Yes	Yes	Yes
Simply Pay	Yes	Yes	Yes

Terminal	P0	P1
Maximum number of controlled machines	Standard: 12 (Maximum: 32, contact us for more)	Standard: 12 (Maximum: 32, contact us for more)
Door / cabinet sheet thickness (mm)	2 / 2	2 / 2
Ergonomics	Wall Mounted	Wall-inserted
Dimensions W × H × D (mm)	500 × 600 × 232	Box: 550 × 900 × 350 Front face: 600 x 950 x 3
Weight (kg)	36	65
Embedded computer	Yes	Yes
Remote update	Yes	Yes
Touchscreen		
Size	22 inches	21.5 inches
Resolution	1920 x 1080 – 50/60 Hz	1920 x 1080 – 50/60 Hz
Impact rating	IK-07	IK-10
Brightness	—	Automatic via sensor: max 1000 nits
Protection	Flexible hybrid glass film	—
Options		
Card dispenser	No	No
Loyalty card	No	No
Remote management	No	No
Paperless invoice	Yes	Yes
Simply Pay	Yes	Yes

2. Technical installation manual

This installation manual is intended for installers who have received training from LM Control. The product must be installed in accordance with the standards in force, by a professional.

2.1. Network configuration prerequisites guide

To check and configure your network, refer to the " network configuration " guide available on the support site in the section " Connectivity and Telemetry "

Scan the QR Code to access
the technical manuals.



SCAN ME

2.2. Upon receipt

When you receive your product, inspect it to ensure that it has not suffered any damage during transport. If you notice any kind of damage, report it immediately to LM CONTROL. Check the contents of the box to make sure you have all items before moving it to its installation site. We recommend keeping the product in its packaging for transport.

2.3. Technical installation

STEP 1 - Unpacking

- Unpack the product carefully by sliding it out horizontally rather than vertically.

Recommendation: Clear the space around the box to make unpacking the product easier. Get someone to help you with handling and installation.

If you notice that an item is missing, contact the LM CONTROL Hotline at: +33 (0)4 72 47 74 00.

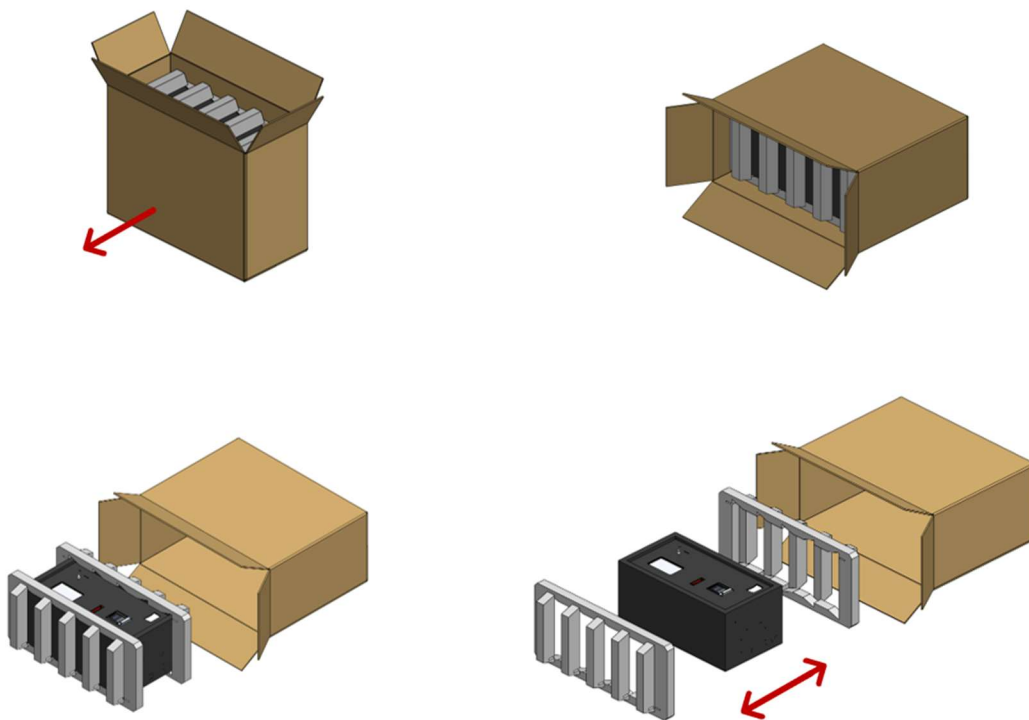

STEP 2 - Mounting

 Protect the electronics (payment system + connector board).

Using a hammer and a center punch, open the pre-drilled cable entry holes you want to use. Strike as close as possible to the attachment points.

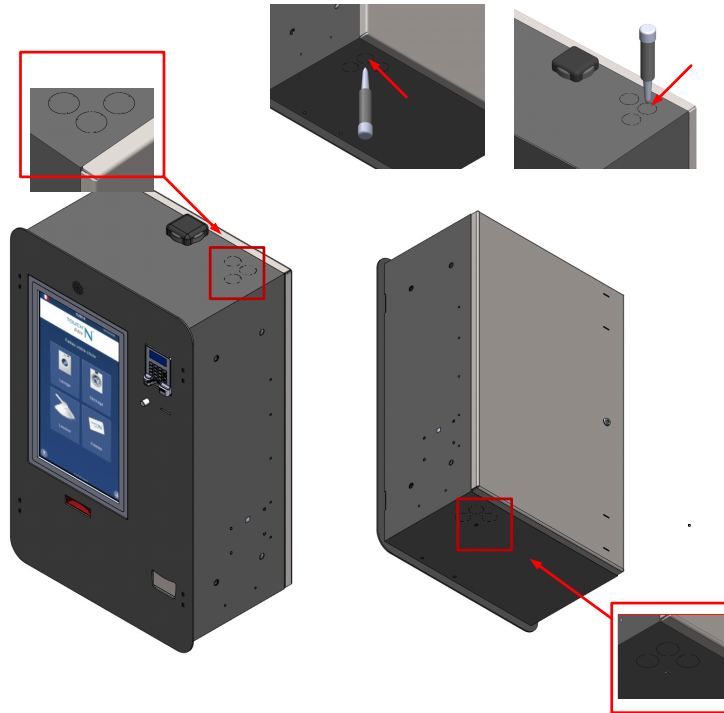

- Remove any excess material using a half-round file, if necessary.
- Retrieve the knockouts that have fallen to the bottom of the enclosure, then vacuum up metal residues.
- Secure the product to the wall and/or install it on the stand (option).

 **Recommendation:** Secure the product to the wall or floor with suitable anchors. These must withstand at least 2 times the weight of the product.
(See appendix for your product drawing)

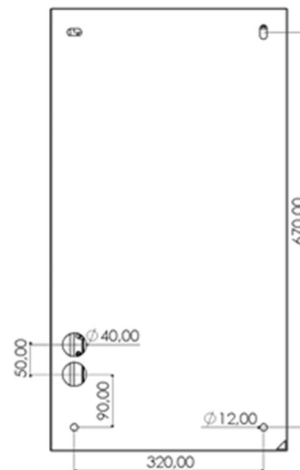

STEP 3 - Preparation and electrical connection



WARNING: All wiring must be carried out with power switched off.
Check that your electrical panel circuit breaker as well as the product breaker are set to OFF.



Route your cables through the previously opened knockouts. If you have brought your cables to the product, follow the connection procedure in the appendix to wire the IEC connector.



Recommendation: Make sure in advance that the circuit breaker can handle the kiosk power supply. Choose a wire length that is sufficient but not too long, to avoid a fire risk.

NOTE: Do not connect the kiosk to a timed power relay. The card reader and the kiosk may need to communicate overnight.

- Connect the supplied IEC power cord to the product power switch input, then connect the other end to a wall electrical outlet.

OR

- Connect the wires you previously brought to the product to the supplied IEC connector, then plug the connector.



STEP 4 – Connecting the Internet network

- Route the network cable through the previously opened knockout.
- Locate the switch, then plug the network cable into port 1.

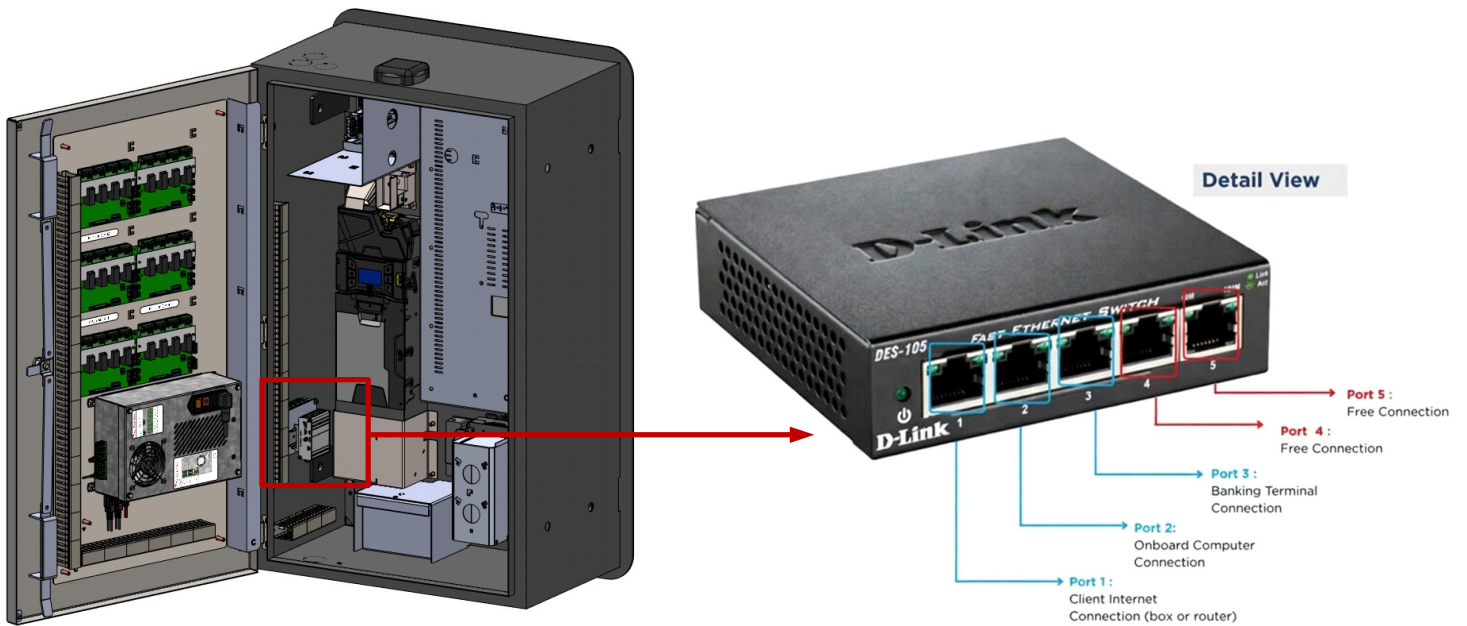

STEP 5 – USB connection

A USB port is located on the left side of the smart box.

WARNING: this port is only used to connect a keyboard in the event of after-sales service intervention with the hotline. LM Control declines all responsibility in case of misuse (connecting a smartphone, USB speaker, ...).



STEP 6 – Optional speaker connection

A 3.5 mm jack extension cable is located on the left side of the smart box.

- If you have subscribed to this option, cut the cable tie, then connect the cable to the speakers.
- Then plug the speakers into an electrical outlet. Run selection tests to adjust the volume level.



STEP 7 – Power on

- Check that all cables are correctly connected to the equipment and that none are left disconnected.
- Set the electrical panel circuit breaker to ON.
- Press the electrical enclosure circuit breaker button to switch it ON.
- Wait until the product has fully started.
- Perform the following checkpoints:
 - The screen turns on.
 - The fan is running.
 - The payment systems turn on.

At the first power-up, the kiosk starts with a factory configuration.
It will be necessary to configure it before commissioning.

If you notice a malfunction:

- Switch the product off by setting the power button to OFF.
- Check the wiring.
- Consult the FAQ.
- If the problem persists, contact the LM Control Hotline after recording the device serial number shown on the nameplate.

STEP 8 – Machine connection

To connect the machines to the LM CONTROL I/O boards, refer to the manual "I/O board – Installation manual" available on the support site in the section "Laundromat payment kiosks"

Scan the QR Code to access
the technical manuals.



SCAN ME

3. Product configuration

Product configuration allows you to adapt the commands to the specific requirements of the operation.

- Make sure that everything is wired.
- Access the programming menu:

Press and hold the date at the top right until the password screen appears.

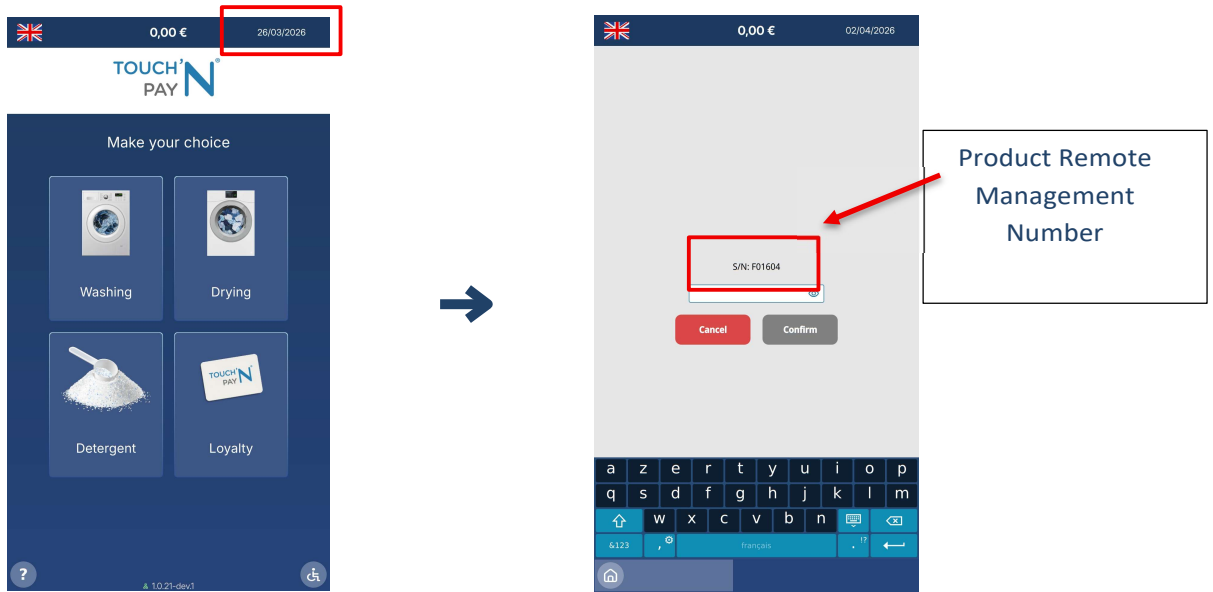

You arrive at the page above

Enter the default password,
then click **“Confirm”**

Password: ***#69330#***



You must change your password

3.1. Diagram of the settings menus

All functions are organized into “menus” with different tabs. The menu structure is shown in the diagram below.

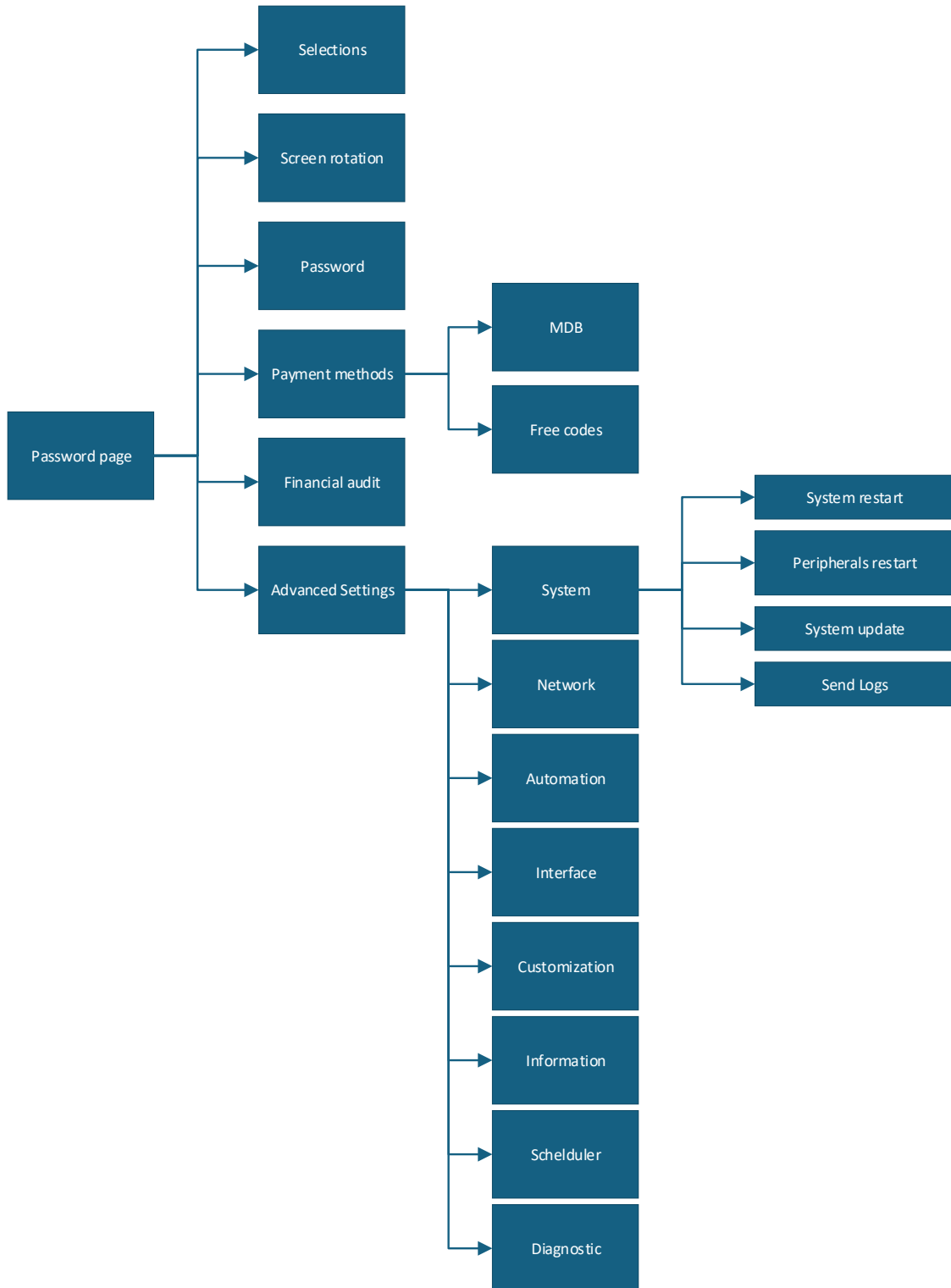

3.2. Main menu

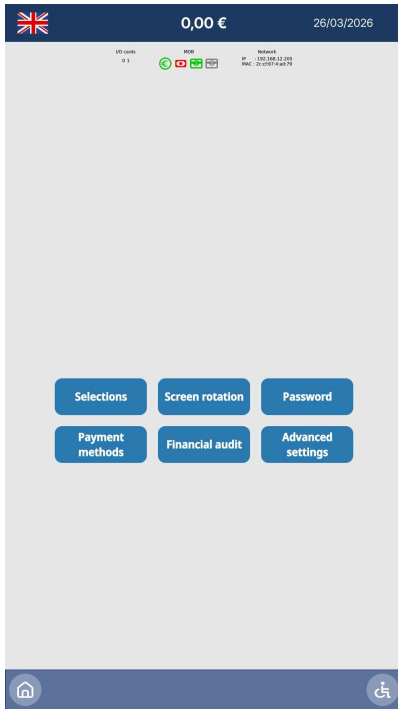

This page groups together the main configuration and management functions:

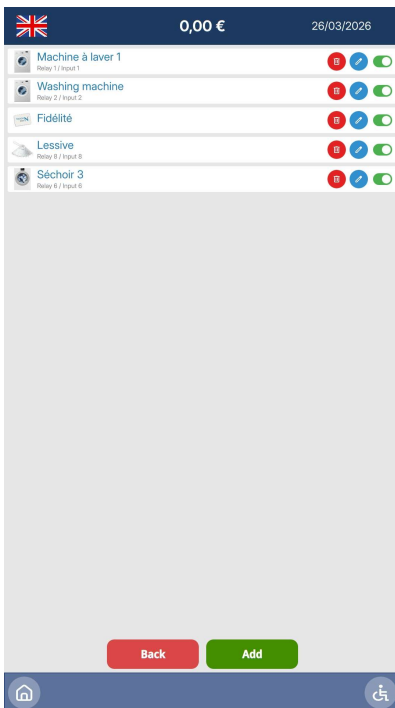

- Selections: Configure the choices offered to the user.
- Payment methods: Configure cash and card payment methods.
- Screen rotation: Adjust the display orientation.
- Financial audit: View interim totals and reset them.
- Password: Change your password.
- Advanced settings: Additional technical settings.

3.3. Selections



This page displays all configured selections.

Each line shows the name and the relay number, as well as three possible actions:

-  **Delete** the selection.
-  **Edit** its settings.
-  **Enable/Disable** the selection.

If no selection has been configured, the screen is blank.

To add a selection, press the “Add” button at the bottom of the page.

 Once all selections have been configured, check that they are programmed on the correct wired relay.

3.3.1. Add / Edit a selection

By selecting add or edit, this screen appears. It allows you to configure a Selection.

Once all selections have been configured, check that they are programmed on the correct wired relay.

0,00 €
26/03/2026

Description ^

Type:

Name:

Typical value: +

Unit:

Mode:

Hidden:

Price ^

Multiple vend: +

Price (c€): +

Discounted price (c€): +

VAT (%): +

Suggested items ^

No item selected Configure

Pulse ^

Auto-hold:

Inverted input:

Simulated return:



Duration (ms): +

Inter-pulse (ms): +

Occurrences: +

Relay/input: +

Back
Apply

3.3.2. Description

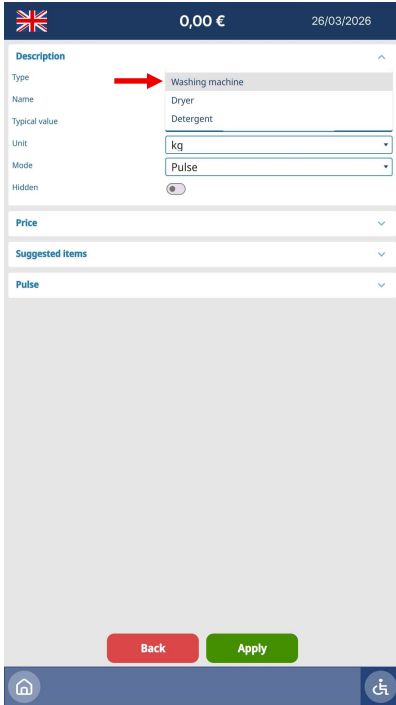

Select the type of selection

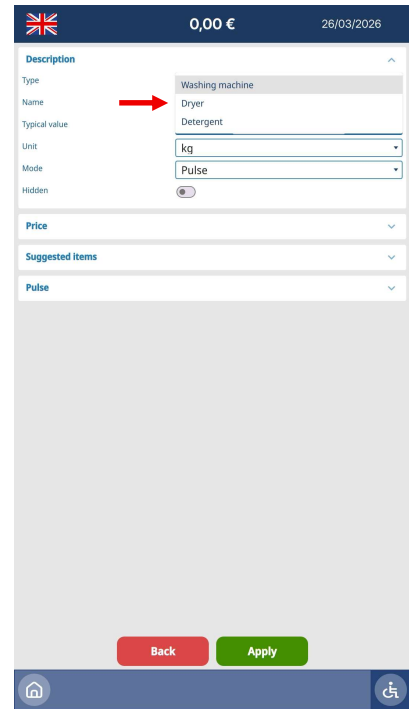

Rename your selection if necessary

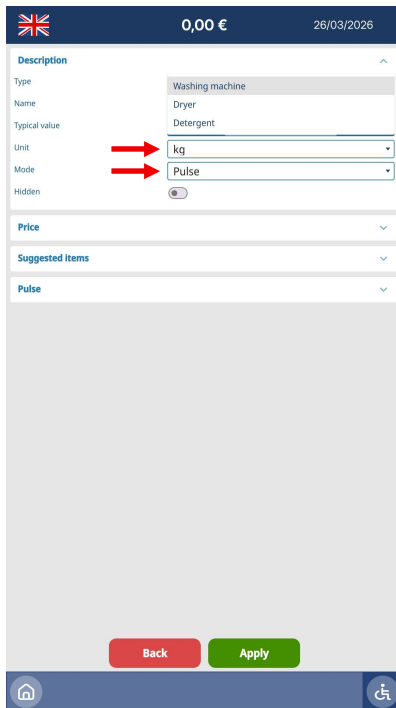

Select the typical value and the unit.



Example:
Enter "3" followed by 'kg' to display "3 kg" in the selection



3.3.3. Price

UK flag | 0,00 € | 26/03/2026

Description ▾

Price ▲

Multiple vend	1	+
Price (c€)	0	+
Discounted price (c€)	0	+
VAT (%)	0.00	+

Suggested items ▾

Pulse ▾

Back Apply

- **Multiple sales:** maximum number of sales in one transaction
- **Price:** Selection amount in cents
- **Discounted price :** Amount of the selection when scheduling enables this discount option
- **VAT:** VAT rate (%) for the selection

3.3.4. Product suggestions

Suggests purchasing a product at the same time as the selection.

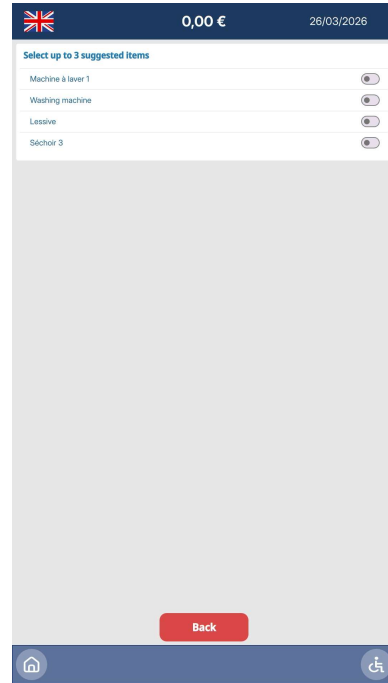
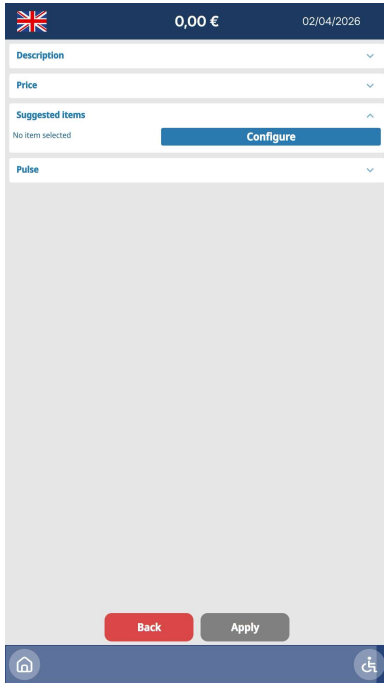

Example:

Offer the purchase of detergent at the same time as the purchase of a washing machine.

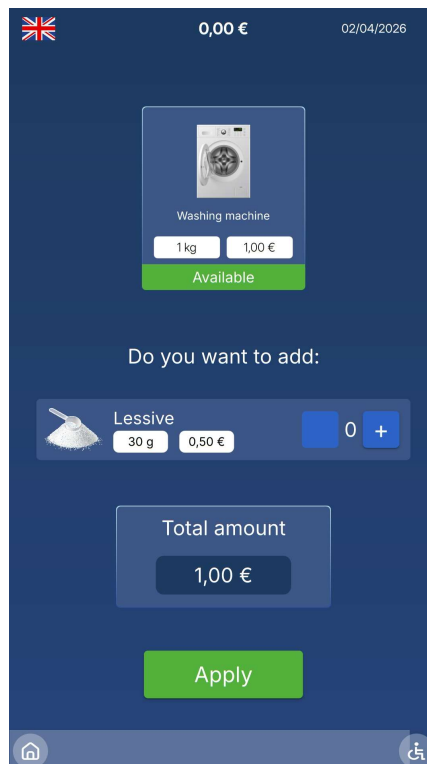

3.3.5. Dry contact mode



Pulse mode (STANDARD)

After a sale, the relay is activated for a defined duration in the " Duration (ms) " field.
The kiosk is unavailable for another sale while the relay is active.

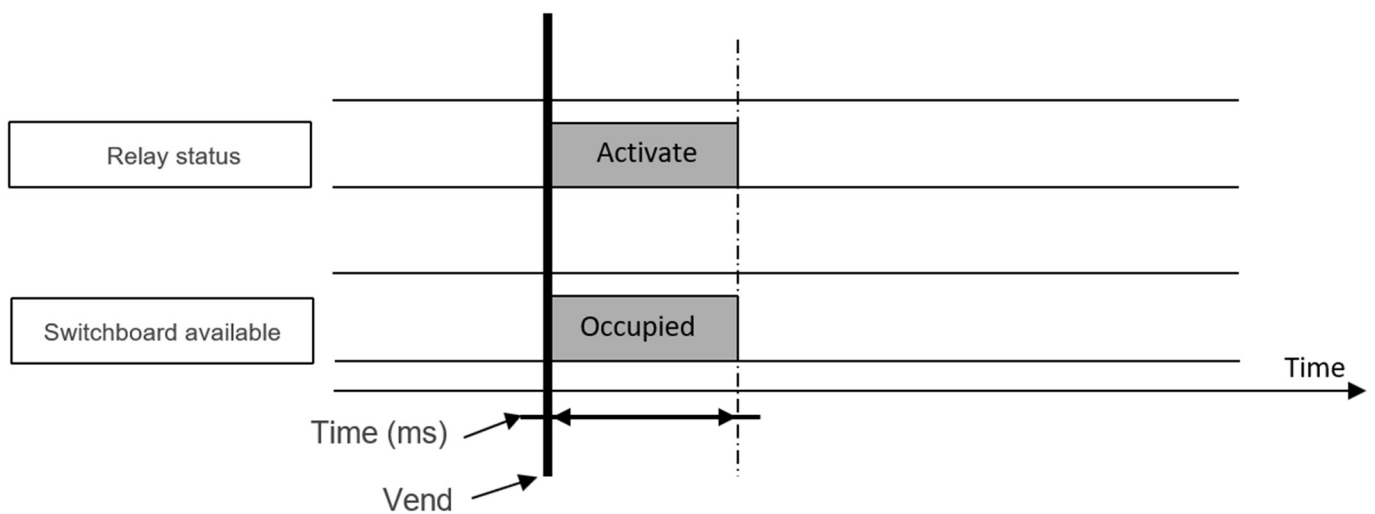

Self-hold mode

After a sale, the relay is activated.

When the machine return signal appears, the relay is deactivated.

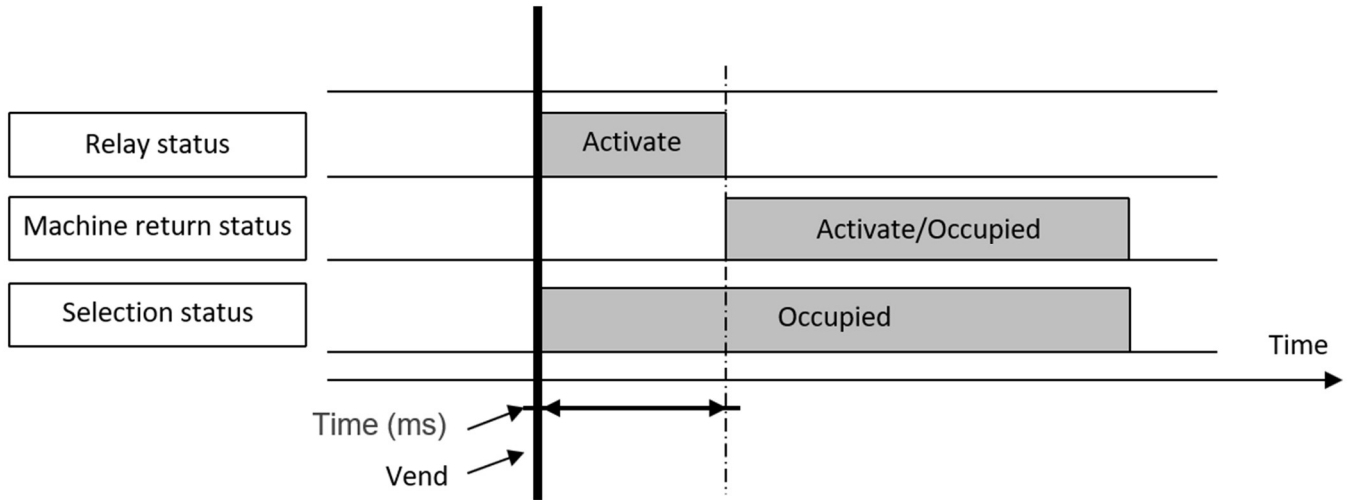

Inverted return mode

After a sale, the relay is activated.

When the return occupancy voltage disappears, the selection is occupied.

The return occupancy information is interpreted in reverse:

- Voltage present: available
- No voltage: occupied

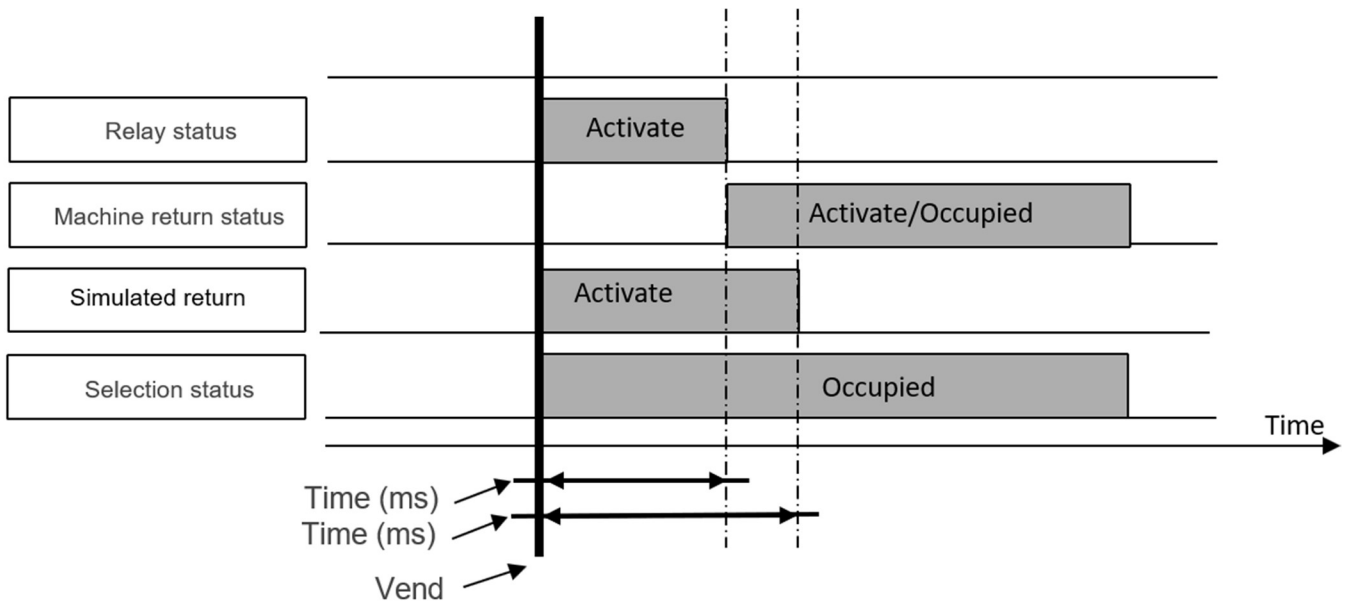

Simulated return mode

After a sale, the relay is activated.

It is deactivated according to the duration configured for the pulse.

During this time, the selection remains occupied thanks to the simulated return, and this occupancy persists until the end of the programmed period, even if the real occupancy return appears in the meantime.

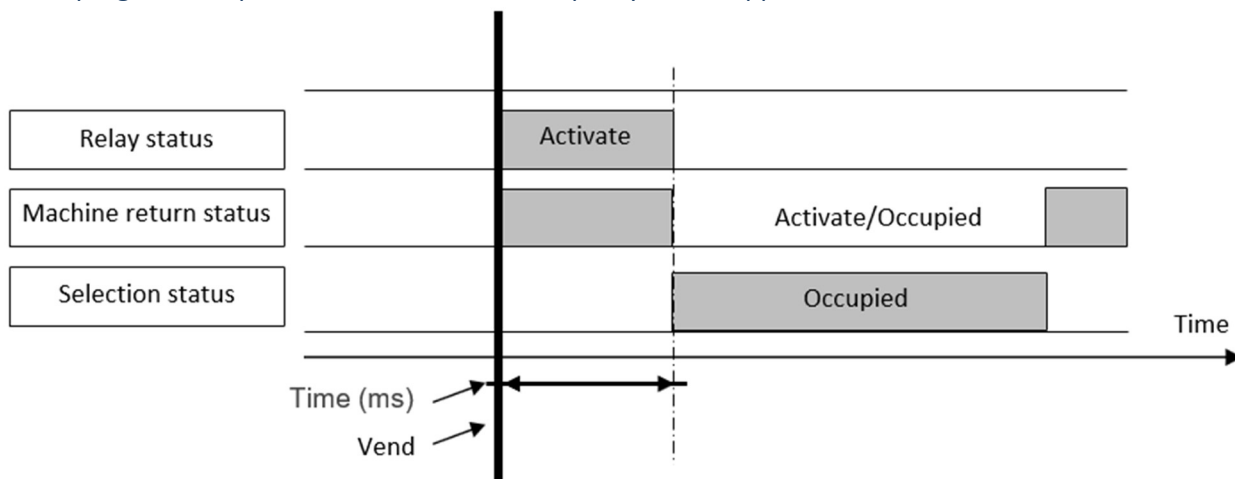

Multi-pulse mode

You need to configure:

- Duration (ms)
- Inter-pulse (ms)
- Number of pulses

During a sale, the relay remains active for the time "Duration (ms)", then stays low for the time "Inter-pulse (ms)" and repeats the operation the number of times specified in "Number of pulses".

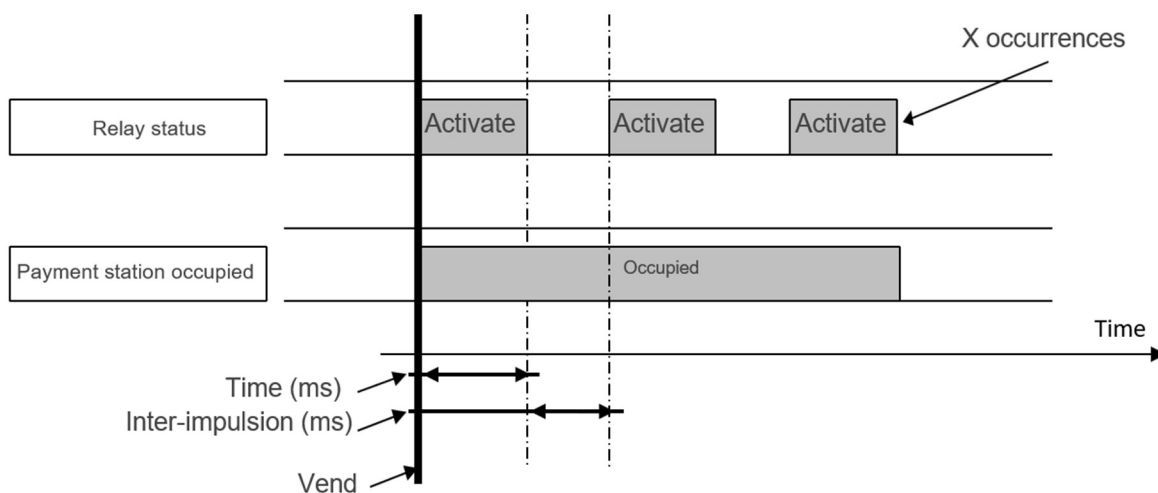

Relay / input

Configure the relay to be controlled here using the configuration set above.

3.4. Screen rotation

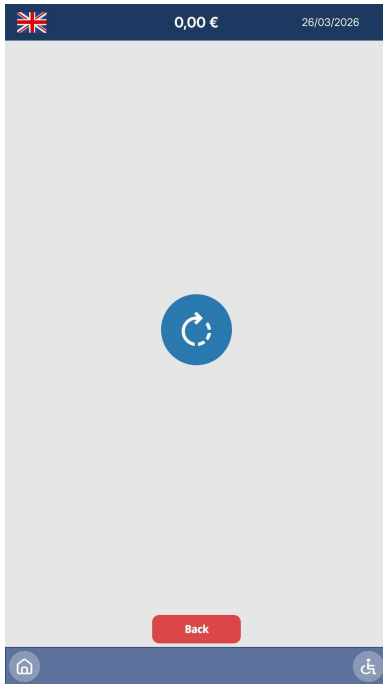

The “Screen rotation” tab lets you adjust the display orientation to suit your needs. Press arrow in the middle to rotate the screen until you get the desired display orientation.



Only perform this operation if the display is not oriented correctly at first startup.



Wait for the screen to finish rotating before pressing again.

3.5. Change the password

The kiosk is supplied with a factory password.

Change this password at first use to ensure the security of the kiosk.

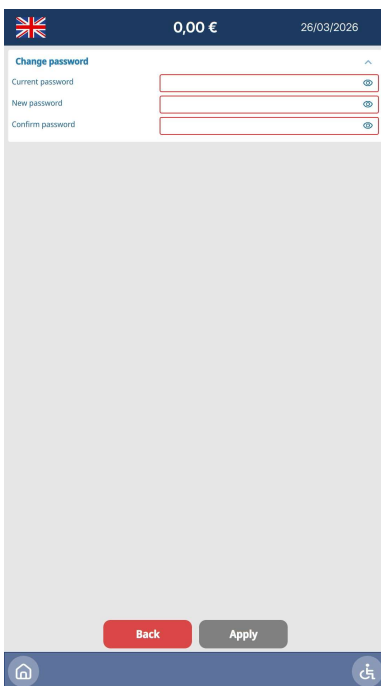

- Enter the current password
- Enter the new password you want to use.
- Confirm the new password
- Press Apply



It is important to write down your new password. There is no “forgot password” function; only LM Control can reset the password within 48 hours.

3.6. Payment methods

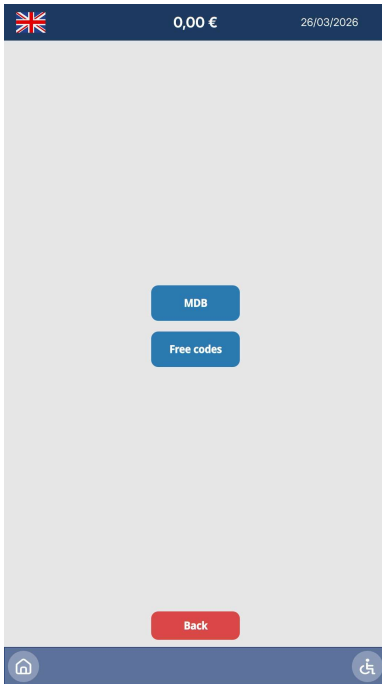

- MDB: to access the MDB payment method
- Free codes: to access the free codes menu

3.6.1. MDB

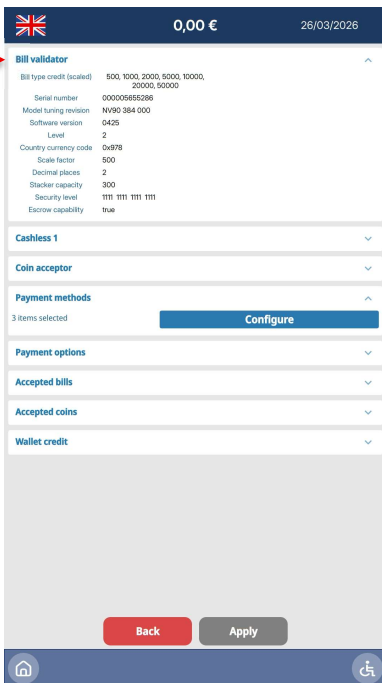

Banknote reader: information related to the peripheral device

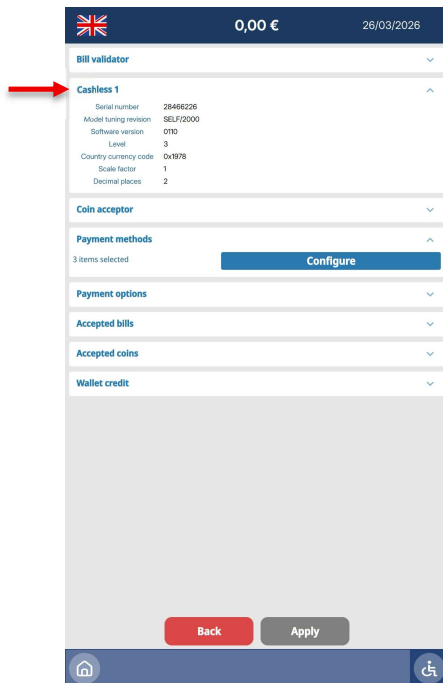

Card reader: information related to the peripheral device

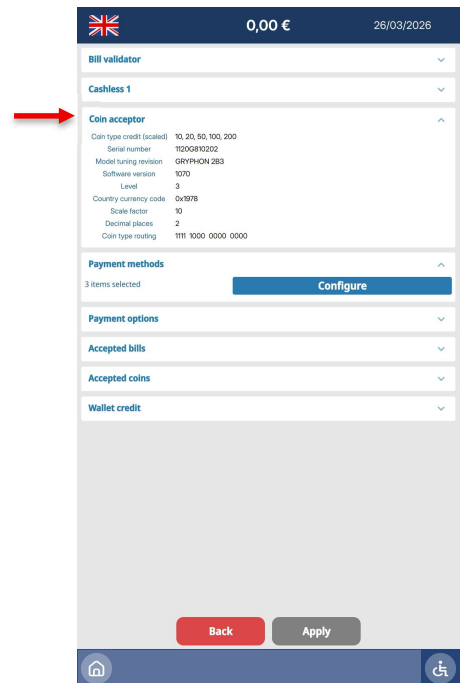

Coin mechanism: information related to the peripheral device

Payment modes

Allow you to select the active payment methods.

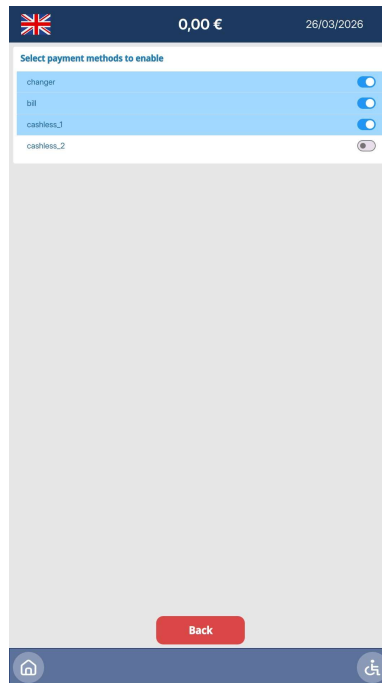

Payment options

- **Overpayment retained:** Keeps the amount not returned as “credit”.
- **Forced sale:** if a customer inserts cash, they are required to make a purchase to receive the change.
- **Preselection:**
 - Preselection enabled: cash insertion will only be available after selecting a service
 - Preselection disabled: the product accepts cash at any time (at the beginning, in the middle, or at the end of the purchase journey).

Accepted banknotes / Accepted coins

Select the coins and banknotes you want to accept.

⚠ Amounts are expressed in cents.

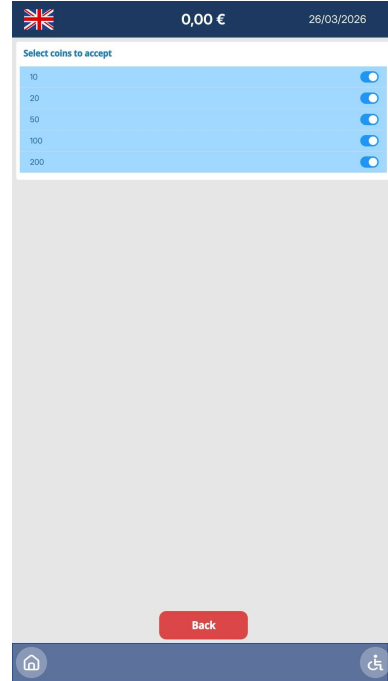
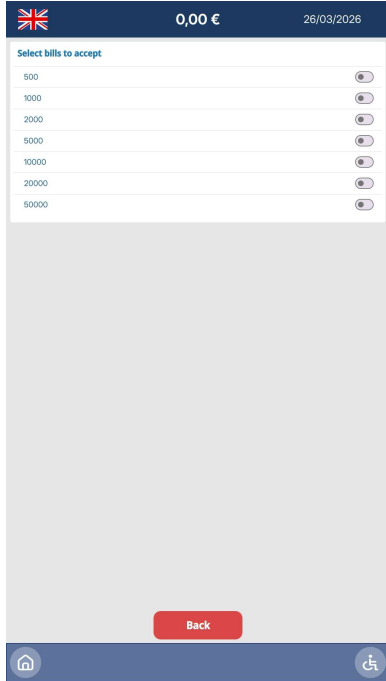

Credit:

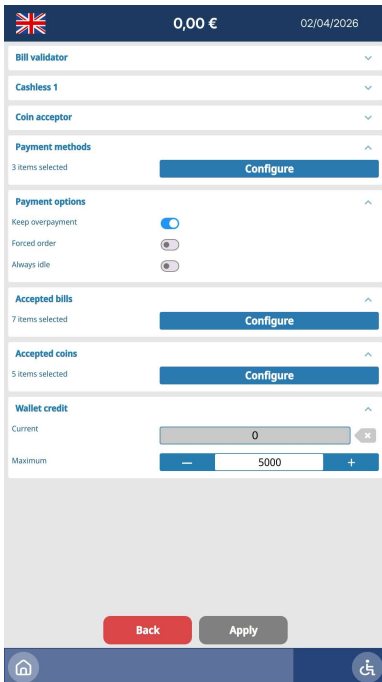

- **Current:** Displays the available credit.
- The button  allows you to clear the credit.
- **Maximum:** maximum amount the payment kiosk can accept.

3.6.2. Free codes

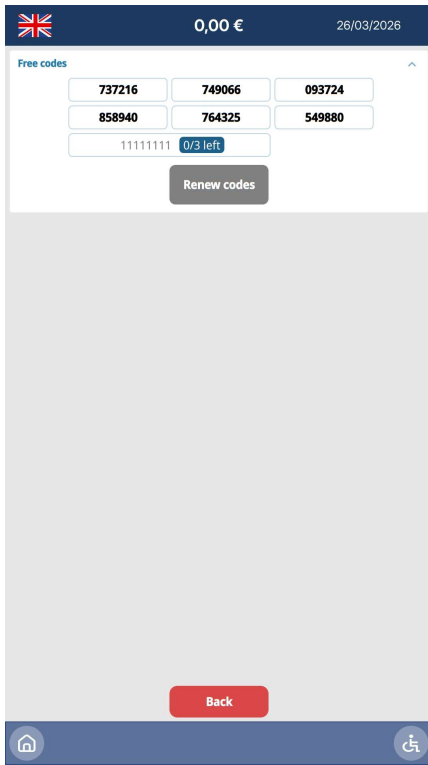

Codes in bold are the available codes.

Codes in grey are codes that have already been used and disabled.

The super code:

- A code at the bottom of the interface has a counter.
- It can be used as many times as indicated.
- It can be configured in the remote control website

Renew codes

- Replaces used codes with new working codes.
- Does not re-credit the super code (this must be done in the remote control).

3.7. Financial Audit

Scan the QR Code to access the technical manuals.



SCAN ME

3.8. Advanced settings

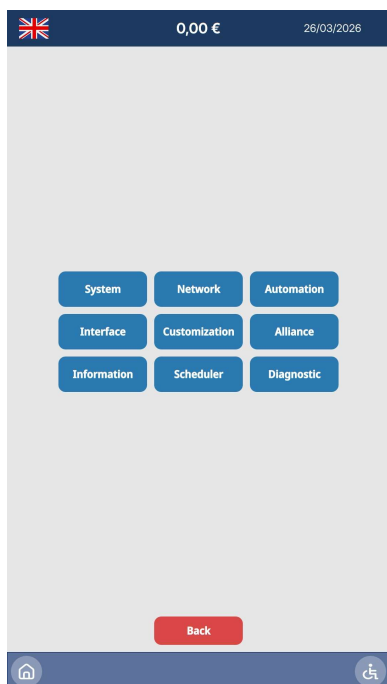

- This screen lets you access more advanced details for configuring the kiosk.

3.8.1. System

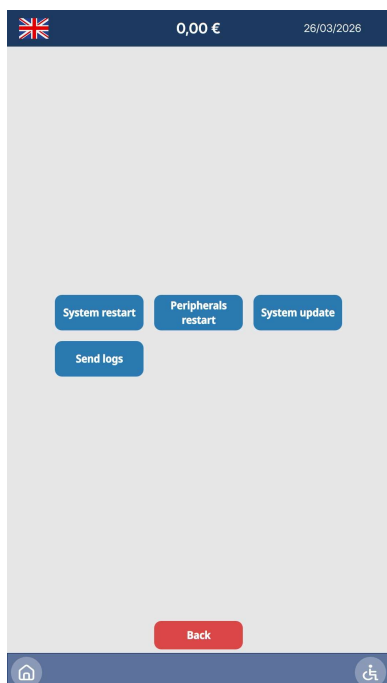

- **Restart the kiosk:** To restart the entire kiosk.
- **Restart peripherals:** To restart peripherals only.
- **Update:** searches for an available update.

3.8.2. Network



IPv4 settings

- Here, you can view the kiosk's network information
 - MAC address
 - IP address
 - Subnet mask
 - DNS1 and DNS2
- You can adjust specific network settings after disabling DHCP mode. (For a static IP configuration, refer to the prerequisites section.)

Connection

- Let's you run a connection test by pinging the specified address.

3.8.3. Automation

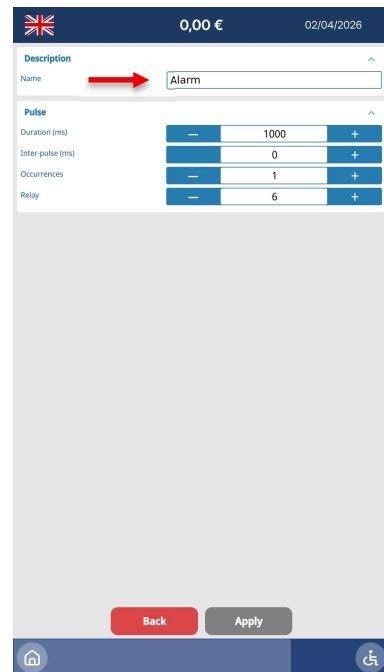
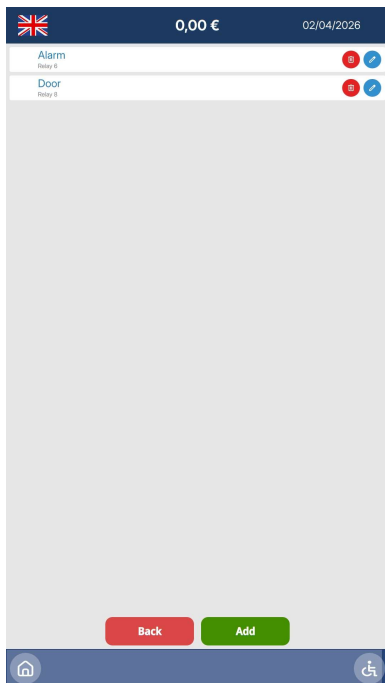

3.8.4. Interface

On this page, you will find all settings related to the date, time, languages, as well as the kiosk volume settings.

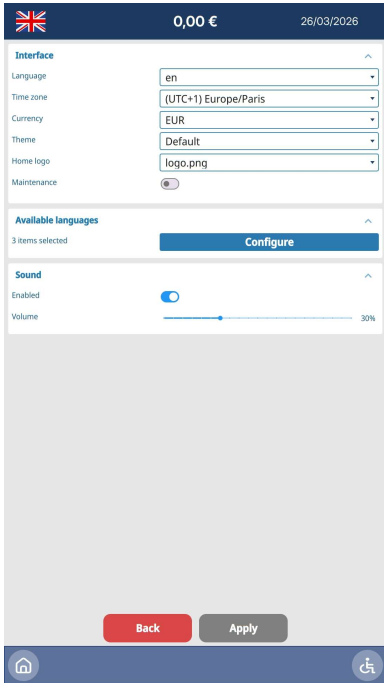

Interface

- **Language:** Default kiosk language.
- **Time zone:** Time zone of the kiosk installation location
- **Currency:** Currency used for payments
- **Theme:** Specific theme available (if developed for the customer)
- **Home logo:** Specific logo for the establishment
- **Maintenance:** Displays a “maintenance” banner.
 - Selections remain active.

Available languages

Configure here the languages available via the flag at the top left.



Sound:

- **Enabled:** Enables and disables sound
- **Volume:** Adjusts the volume level

3.8.5. Display

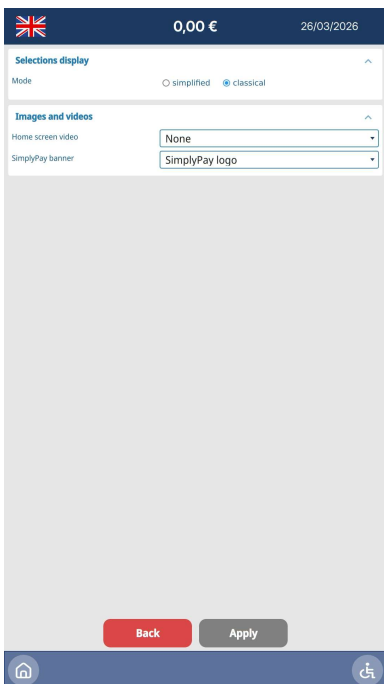

Displaying selections:

Simplified

All selections are visible



Classic

The selections are grouped by type

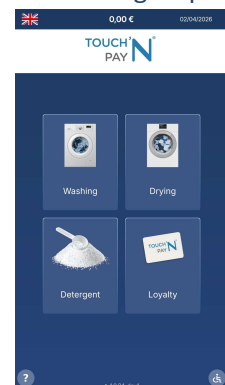

Images and Videos

On this page, you can choose the display format as well as the videos and logo to be displayed.

3.8.6. Information

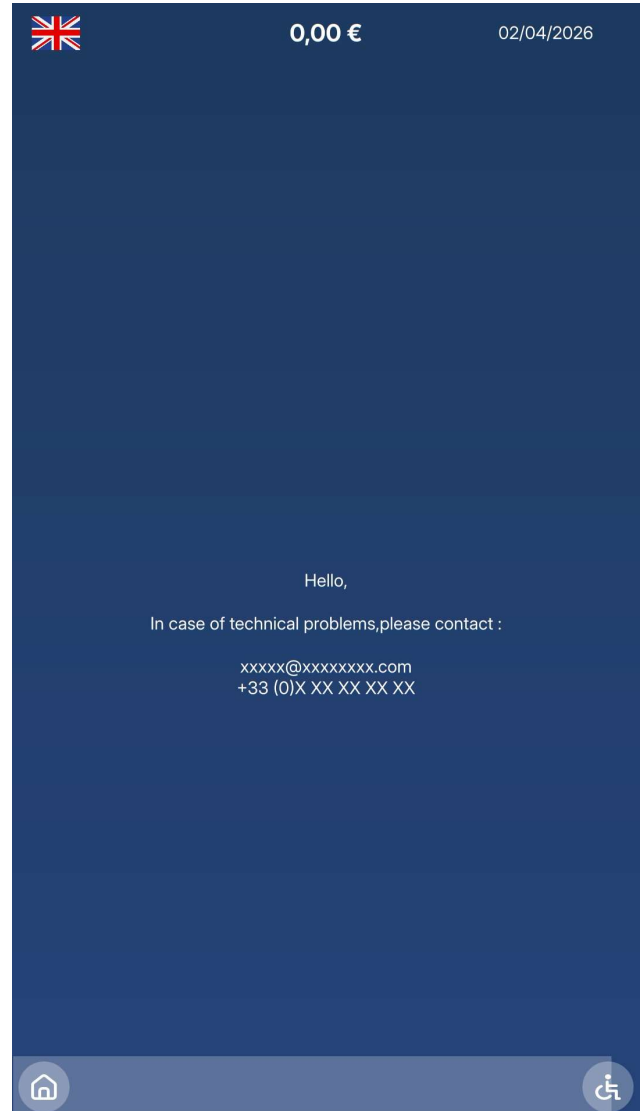
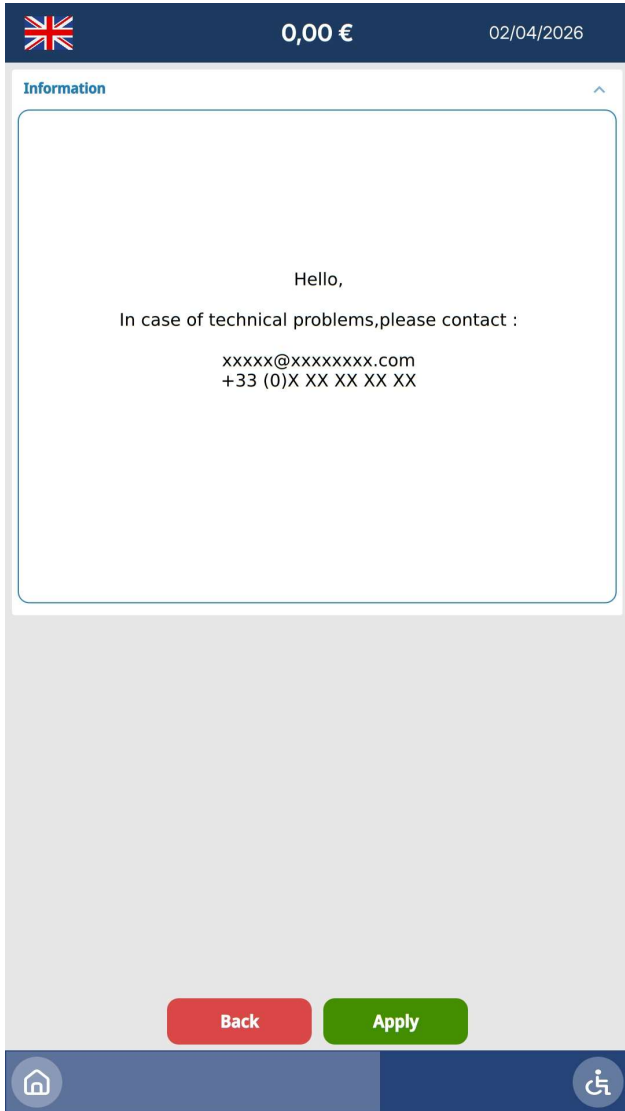

On this page, you can enter information about your laundromat, kiosk, after-sales service, or any other information that may be useful for the customer.

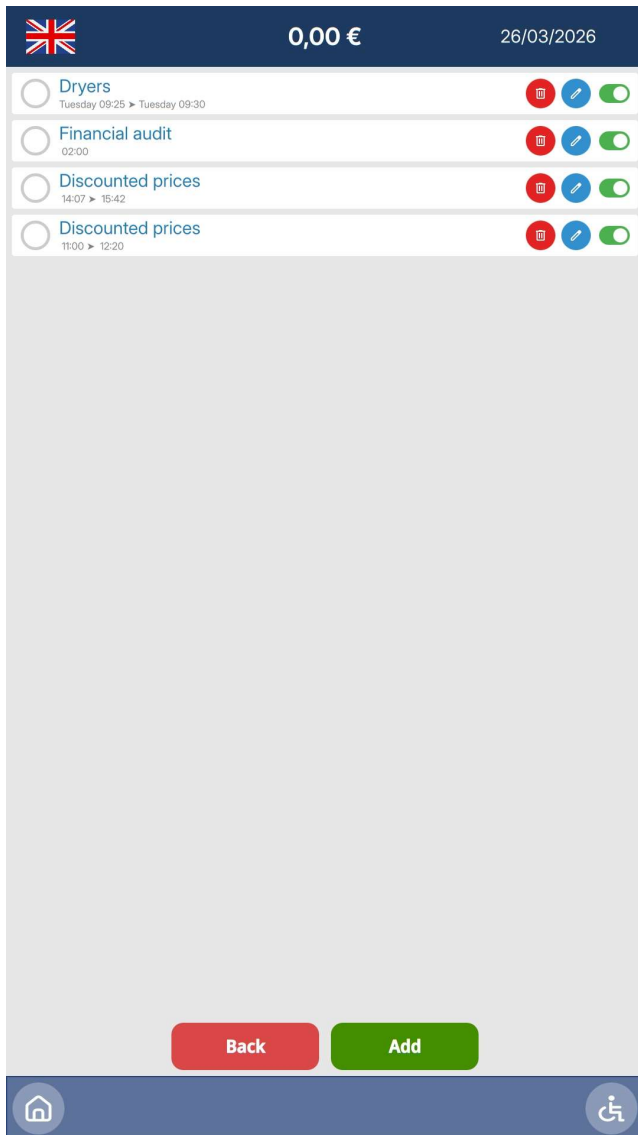

3.9. Scheduler



This page displays all configured actions. Each line shows the name, as well as three possible actions:

-  **Delete** the selection.
-  **Edit** its settings.
-  **Enable/Disable** the selection.

If no action has been configured, the screen is blank. To add an action, press the “Add” button at the bottom of the page.

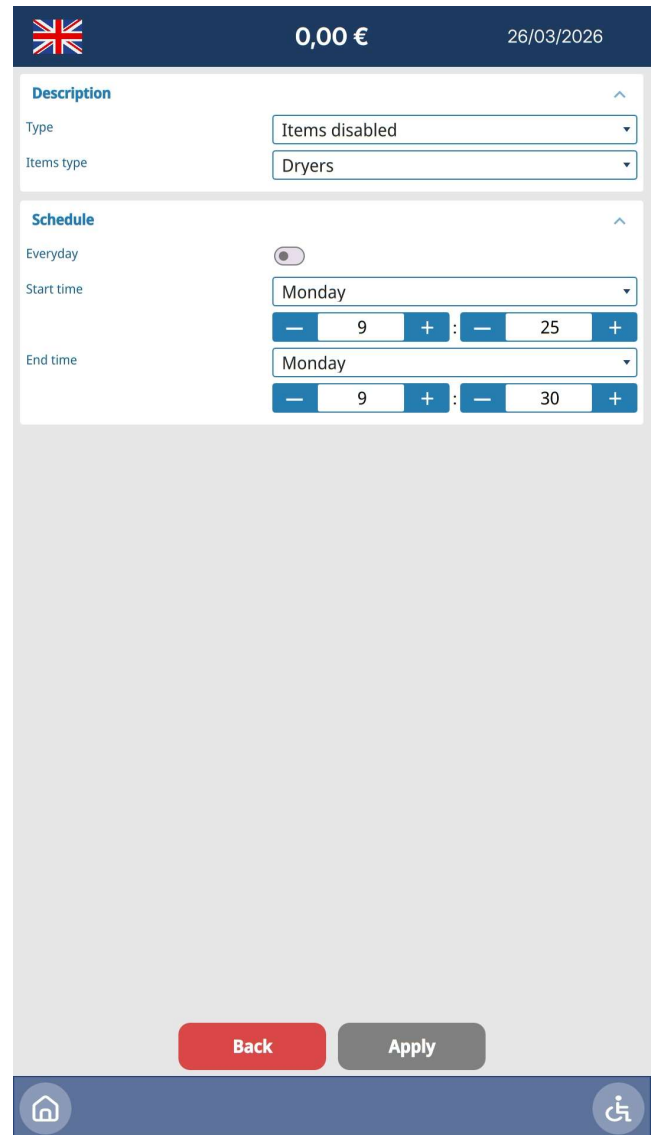

This screen lets you set up an action based on a time criterion.

Type: lets you set the desired action type.

Selection types: lets you apply the action to the selected product category.

Example: disable the machine

Example: standby mode

Type:

- **Selection disabled:** disables selections during the period
- **Standby mode:** turn off the screen
- **Discount:** applies for reduced price for selections during the period
- **Financial audit:** the kiosk generates and sends its report to remote control

Example: machine discount

Example: sending an information report

Select the start and end days for the action.

Set the start and end times for the action.

3.10. Diagnostics

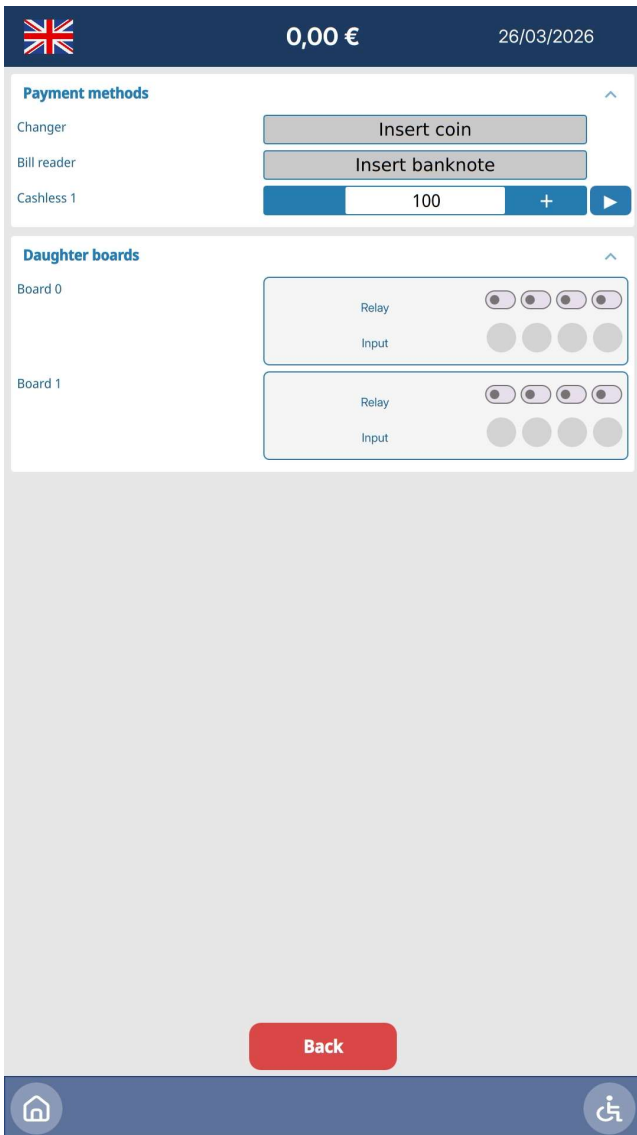

This page lets you test the entire kiosk and all its equipment.

Payment mode:

- **Coin acceptor:** The credit for inserted coins is displayed here
- **Banknote reader:** the credit for inserted banknotes is displayed here
- **Cashless 1:** + and – allow you to adjust the price
- Starts the request on Cashless 1



Warning: the cashless test will charge for real the bank card

Daughter boards:

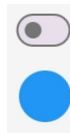

Allows the relay to engage

Allows to view the return status

4. User manual

4.1. MENU overview

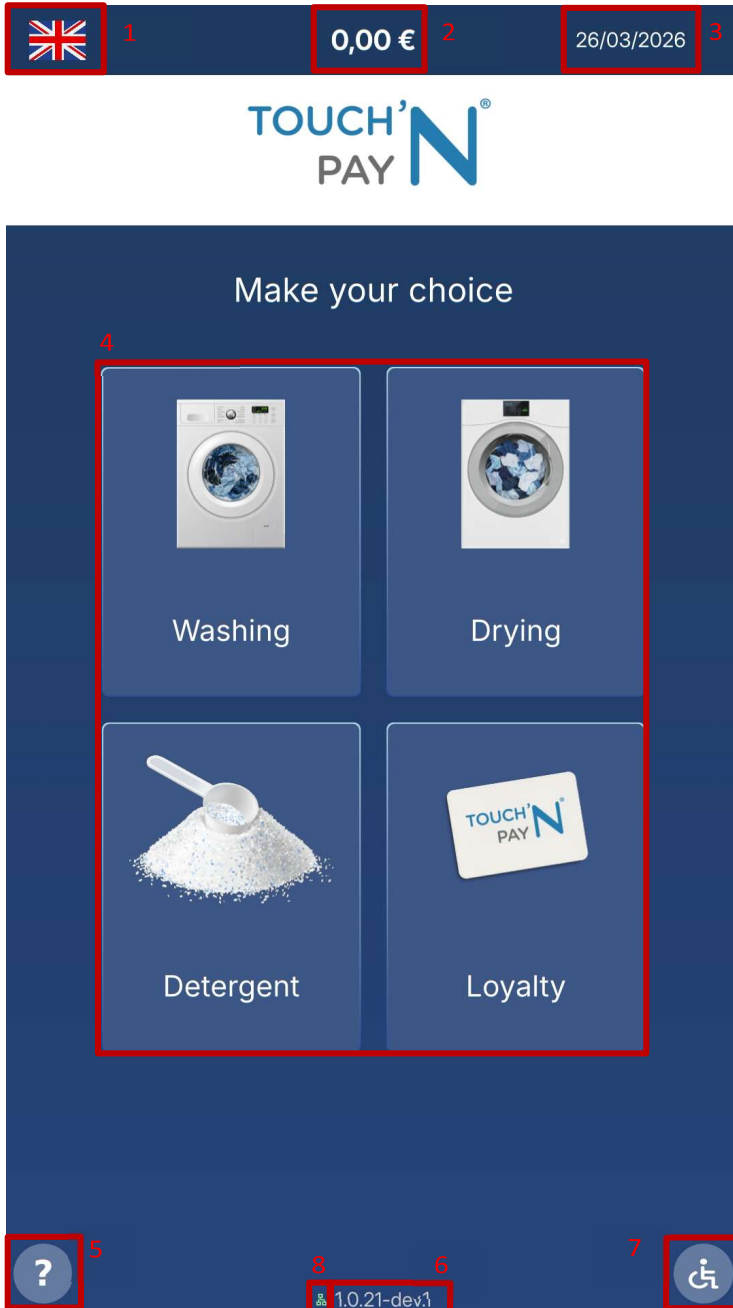

1. Language selection
2. Balance in the kiosk
3. Date
4. Suggested selection
5. Information
6. Kiosk version
7. Accessibility button (PWD)
8. Indicates whether a network connection is present

4.2. Drying mode (Multiple sale)

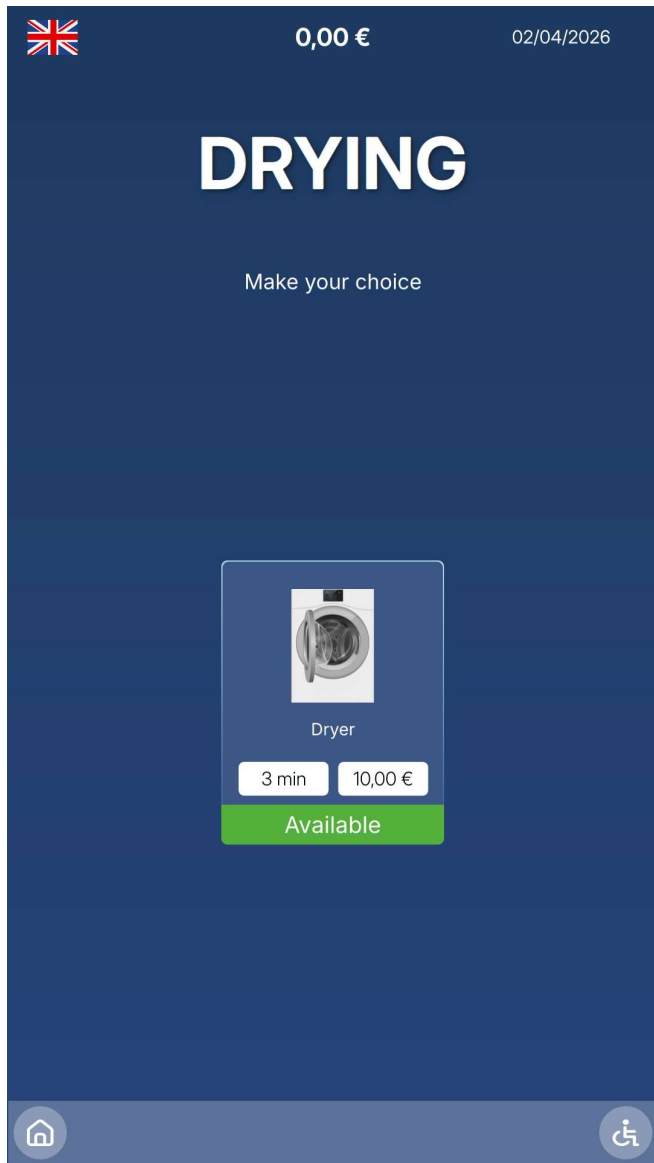

Select the desired machine

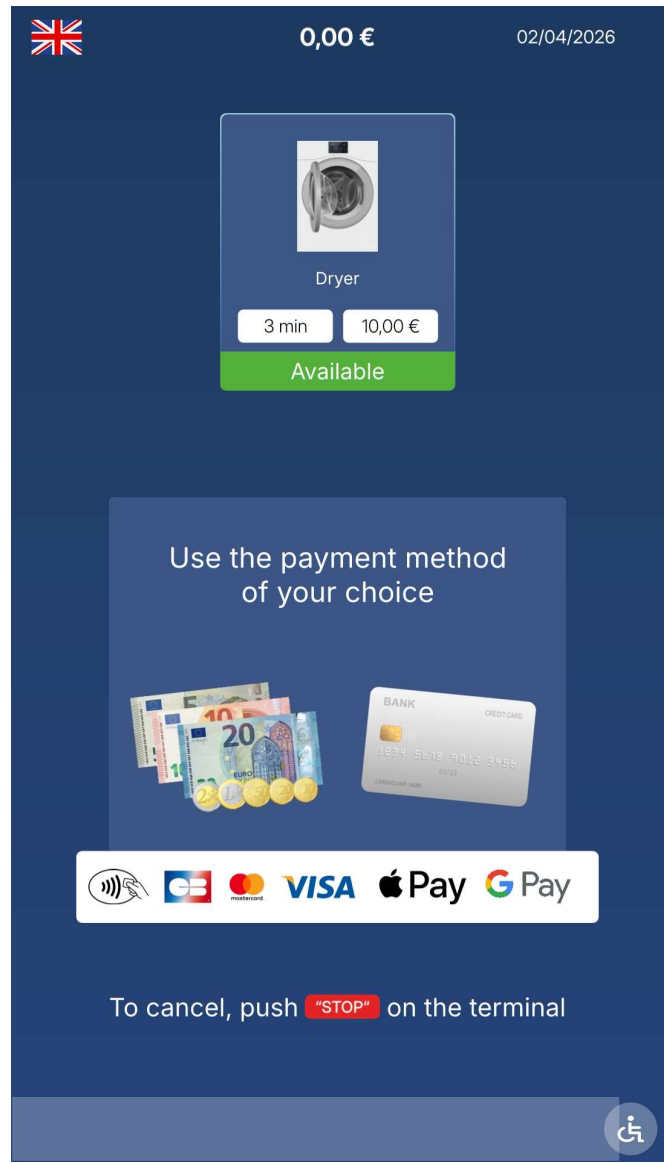

You can select the desired number of cycles

4.3. Payment

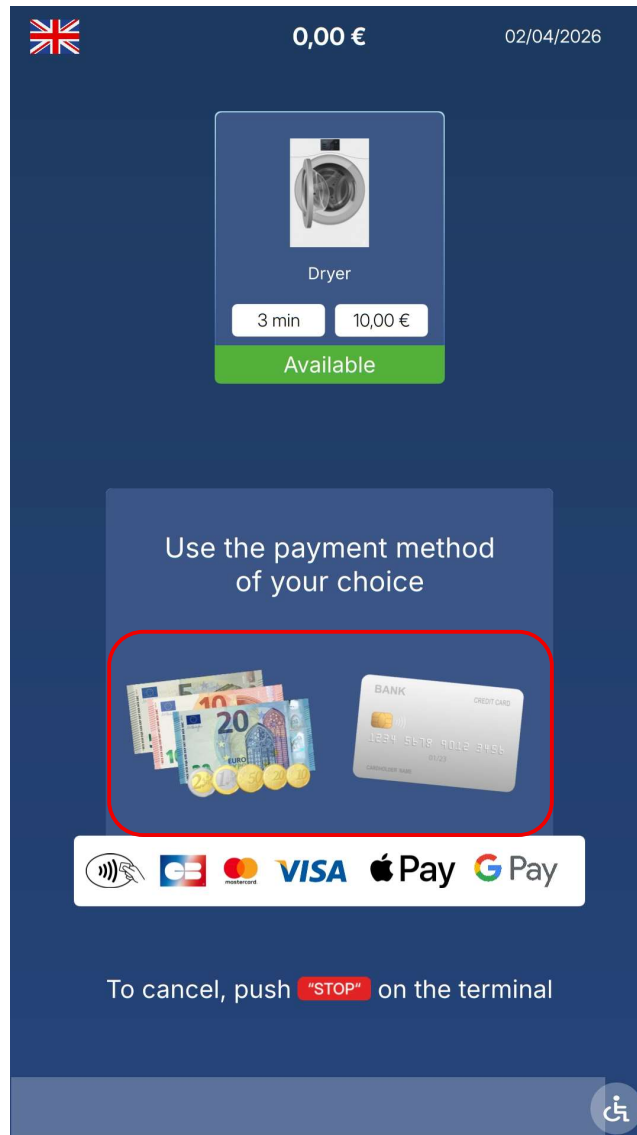

The kiosk displays the programmed and available payment methods:

- Banknotes
- Coins
- Card

If a payment method is missing, refer to the FAQ.

4.4. Payment accepted / declined

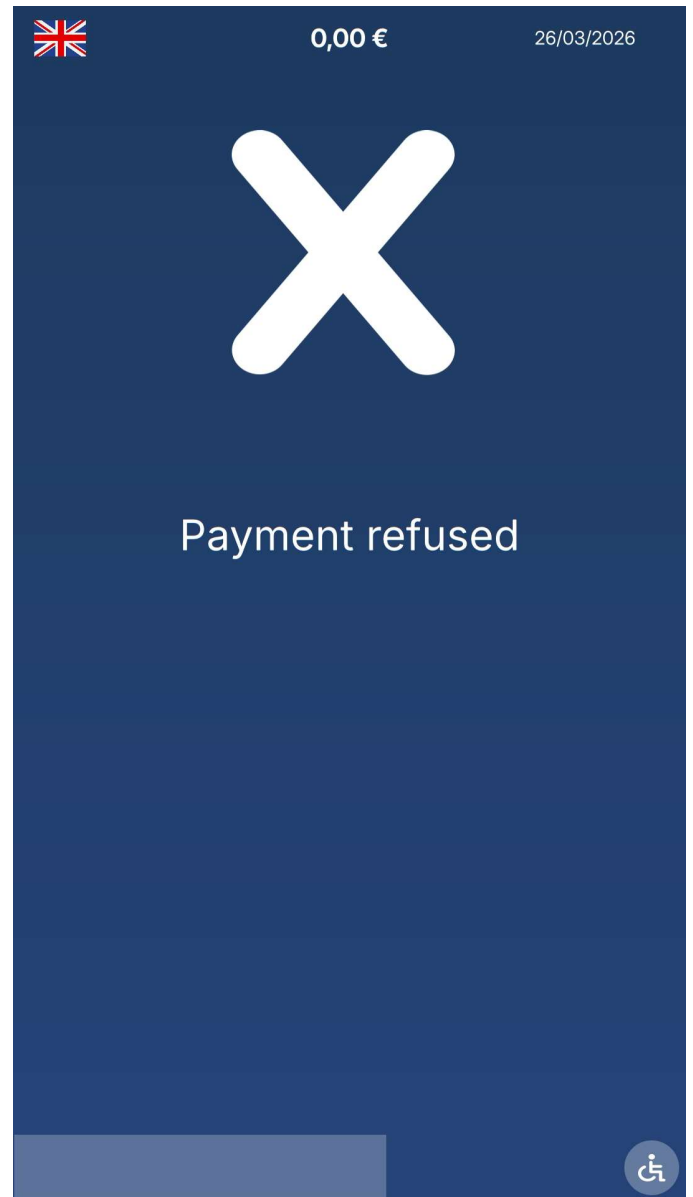
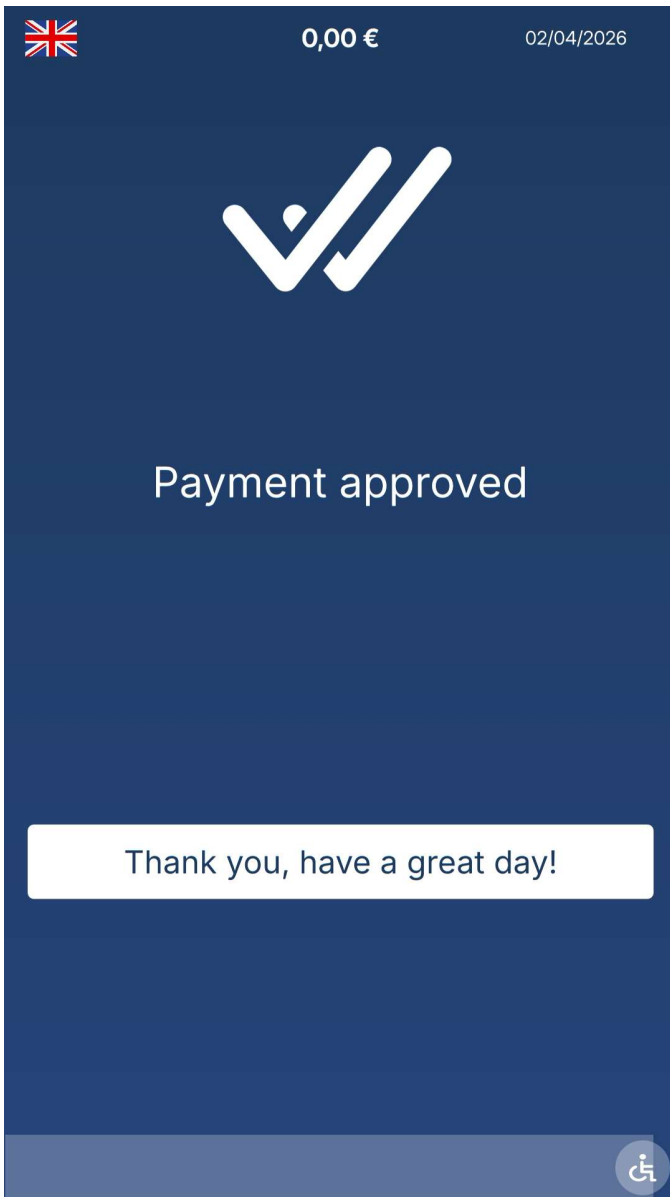

4.5. Using a free code

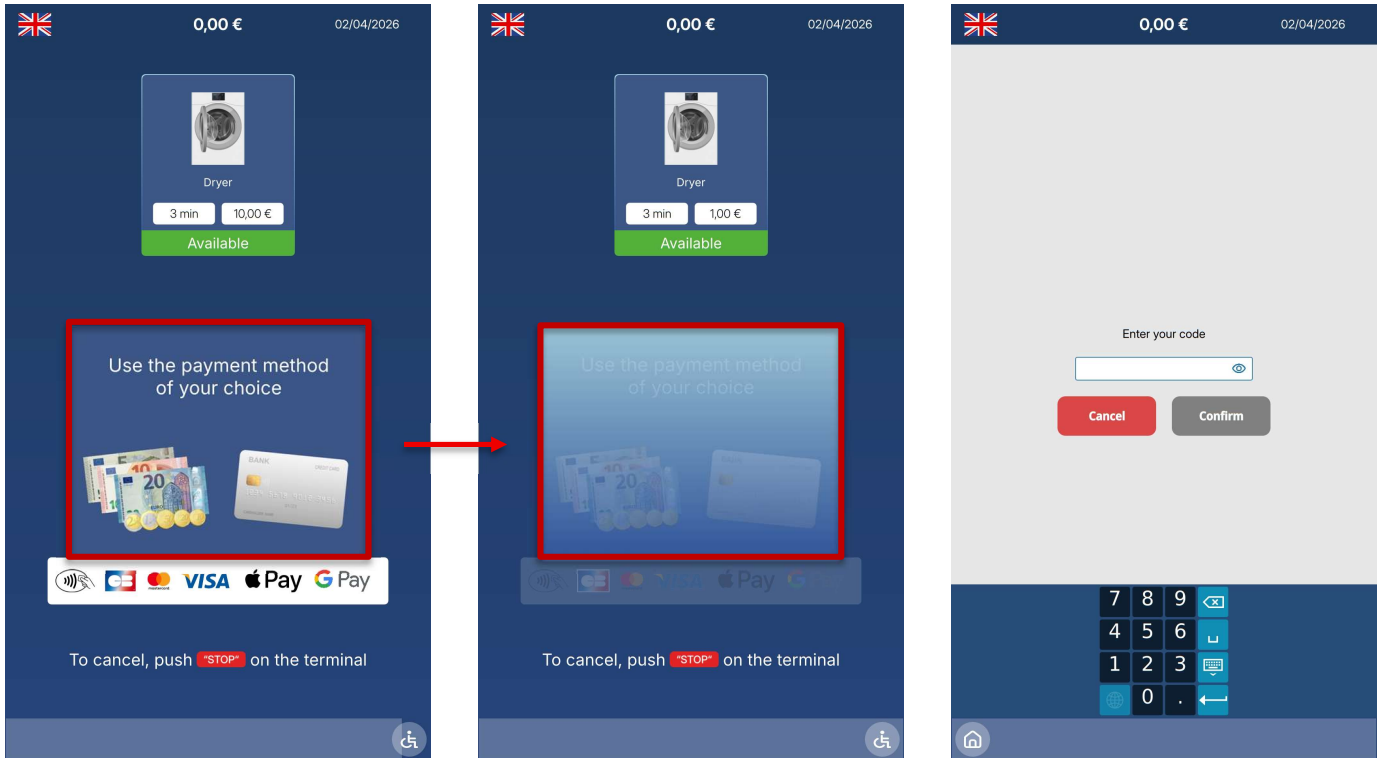

Press and hold the area shown above until the free code menu appears.

- The selection will gradually become whiter before the menu appears. Then enter the free code

5. Maintenance

Regular maintenance must be performed on the kiosk to ensure it operates correctly and to reduce the risk of malfunctions. Refer to the various manuals for your equipment to ensure it operates properly.

5.1. Cleaning and maintenance

We recommend cleaning the screen at least once a week. Before cleaning, switch off the device. Use only a damp cloth or our referenced products.

5.2. Coin acceptor unit cleaning

To maintain your coin acceptor, refer to the manual "maintenance and cleaning" available on the support site in the section "**Banknote reader / Coin acceptor**"

Scan the QR Code to access
the technical manuals.



SCAN ME

5.3. Banknote reader cleaning

To maintain your banknote reader, refer to the manual “NV9 Banknote Reader – Maintenance and cleaning” available on the support site in the section “**Banknote reader / Coin acceptor**”

Scan the QR Code to access
the technical manuals.



SCAN ME

5.4. Card dispenser cleaning

Scan the QR Code to access
the technical manuals.



SCAN ME

6. FAQ-Frequently asked questions

Why won't my kiosk turn on?

- Check the 220 V supply / ON/OFF switch
- Check the PC power wiring

Why is the screen not displaying anything?

- Check the power connection
- Make sure the screen is on: press the ON button on the programming remote control
- Check the HDMI connection

Why is the screen frozen?

- Check the power connection
- Check the HDMI connection
- Check the USB connection

Why won't the payment systems turn on?

- Check the MDB wiring:
 - From the remote control, perform a reset of the payment systems
 - From the remote control, perform a full kiosk reset
 - Power-cycle the kiosk (switch off, then back on)

Why can't I see my kiosk on the Touch'N Pay website?

- Contact the LM CONTROL hotline to verify the kiosk assignment

Why can't I control my kiosk remotely?

- Check that the Ethernet network is available in the room
- Check the Ethernet connection to the PC

Why can't I pay with cash?

- Check the status of the coin acceptor:
 - Power
 - Jam
 - Wiring/Connections
- Check the status of the banknote reader:
 - Power
 - Jam
 - Wiring/Connections

Why won't my banknote reader accept any banknotes?

- Check the status of the banknote reader
 - Power
 - Jam
 - Wiring/Connections
- Check the LED status: if they are blinking, refer to the banknote reader manual

Why can't I pay by card?

- Check the status of the card reader

Why isn't the loyalty card dispenser working?

- Check its connection
- Make sure cards are present in the card dispenser
- Check that the "inverted return" setting is disabled in the *Selections* tab

7. Annexes

7.1. Connecting the IEC connector



WARNING: for safety reasons, all connections must be carried out with the power switched off. Make sure that the electrical panel circuit breaker is set to OFF and locked out, and that the device circuit breaker is also set to **OFF**.



Recommendation: make sure beforehand that the circuit breaker can handle the product power supply, and choose a wire length that is sufficient but not too long.



Screwdriver



Cable stripper



Wire stripper



Crimping pliers



IEC socket



Ferrule (if wire is not solid) x 3



Size 4

1. Using a size 4 flat-head screwdriver, unscrew the IEC socket screw. Then keep the cover and the screw.



2. Using a cable stripper, strip the cord over 5 cm.

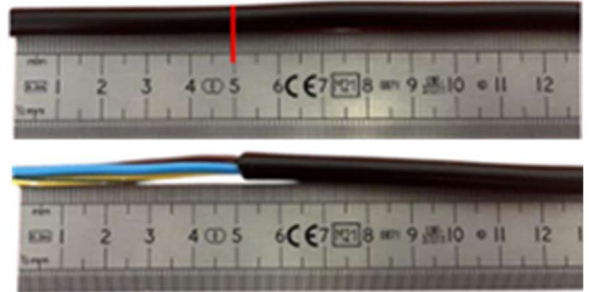

3. Using a wire stripper, strip each wire of the cord by about 10 mm.
For solid wires, limit stripping to 5 mm.

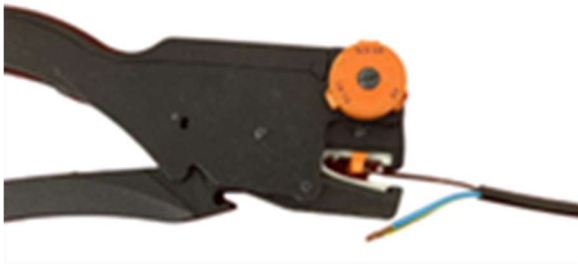

4. Place the ferrules on each wire.
For solid wires, go directly to the next step.

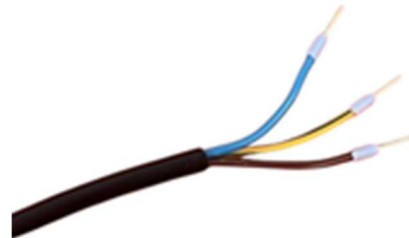

5. Using the crimping pliers, crimp the ferrules. For solid wires, go directly to the next step.

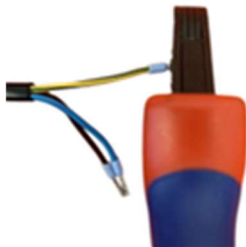

6. Pass the wires through the cable gland. For solid wires, resume from this step.



7. Using a size 4 flat-head screwdriver, unscrew the cable clamp on the connector.



8. Then lift the cable clamp.



9. Using a size 4 flat-head screwdriver, unscrew the terminal block screws.



10. Pass the wires through the cable clamp.

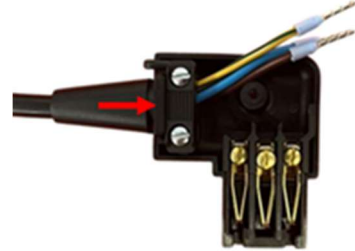

11. Position the cable gland in the insert.

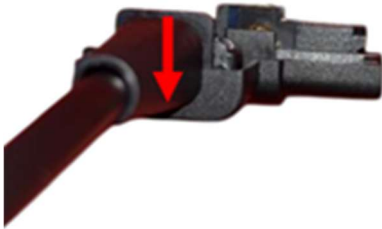

12. Using a size 4 flat-head screwdriver, position the ferrules in the connectors and tighten them to hold them in place.

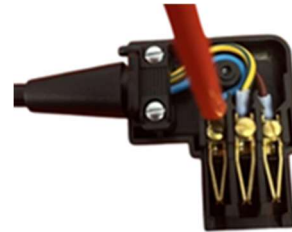

13. After tightening, place the wires according to the arrangement shown below.



14. Using a size 4 flat-head screwdriver, screw the cable clamp back on, leaving sufficient cord slack.

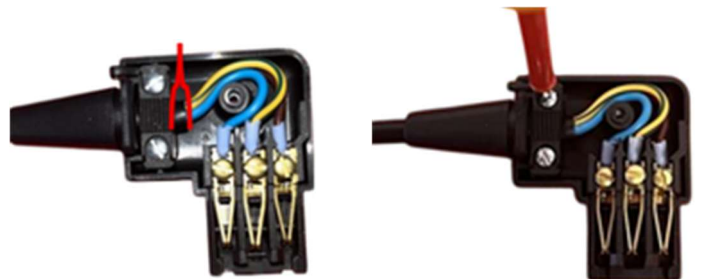

15. Using a size 4 flat-head screwdriver, screw the connector cover back on.



7.2. TNP-SL Kiosk – Wall Mounted

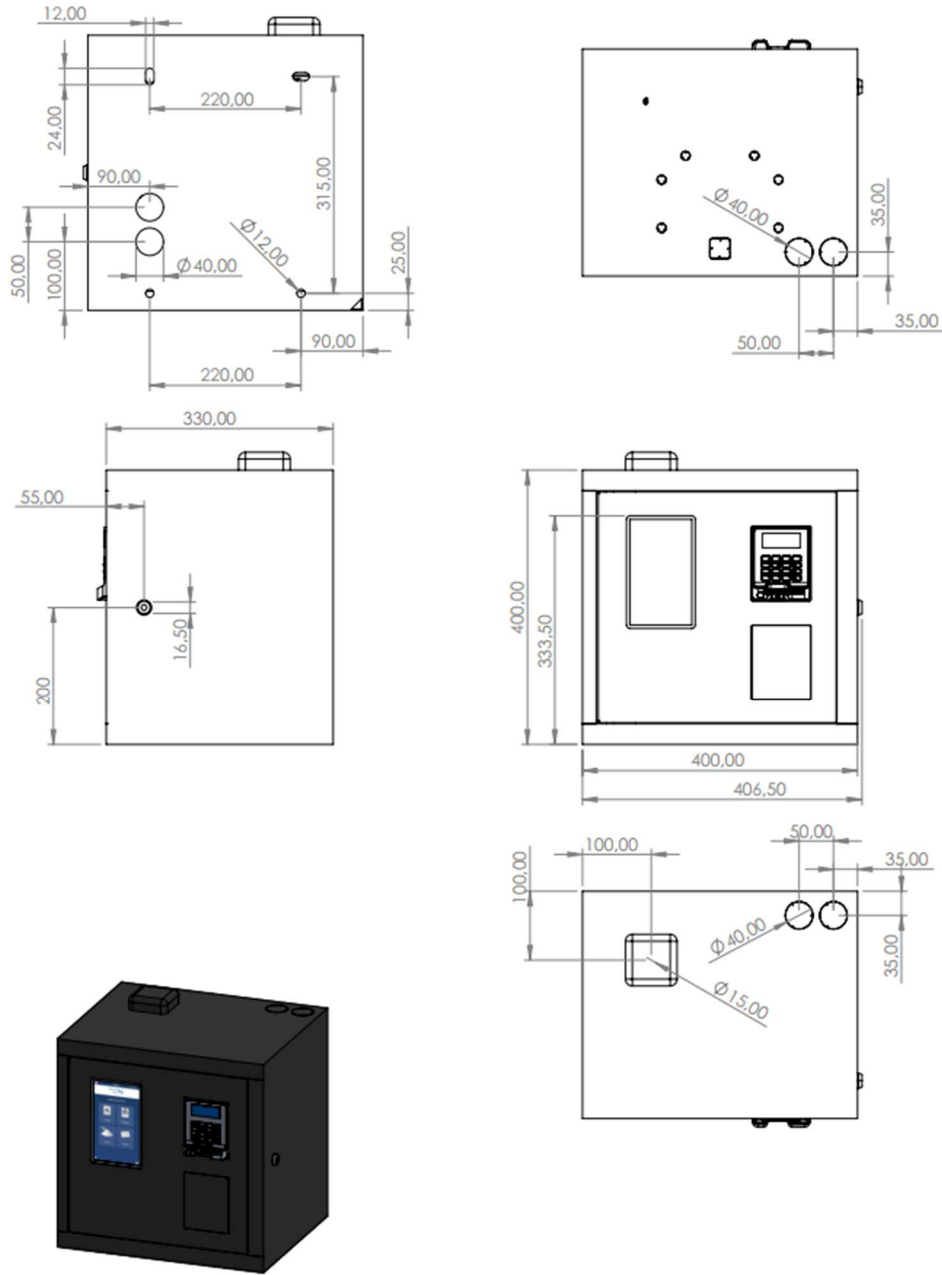

7.3. TNP-L0 Kiosk – Wall Mounted

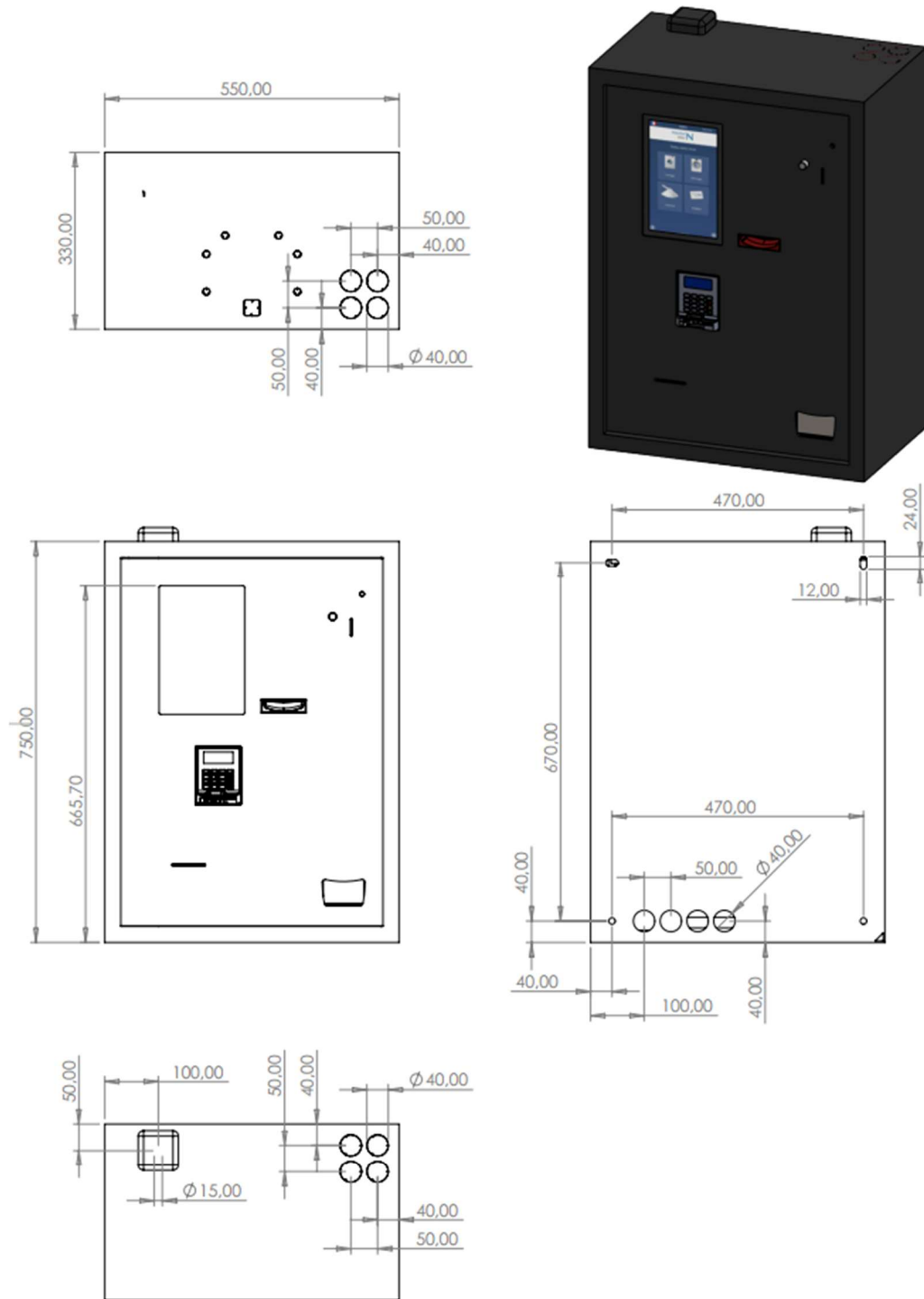

7.4. TNP-L1 Kiosk – Wall-inserted

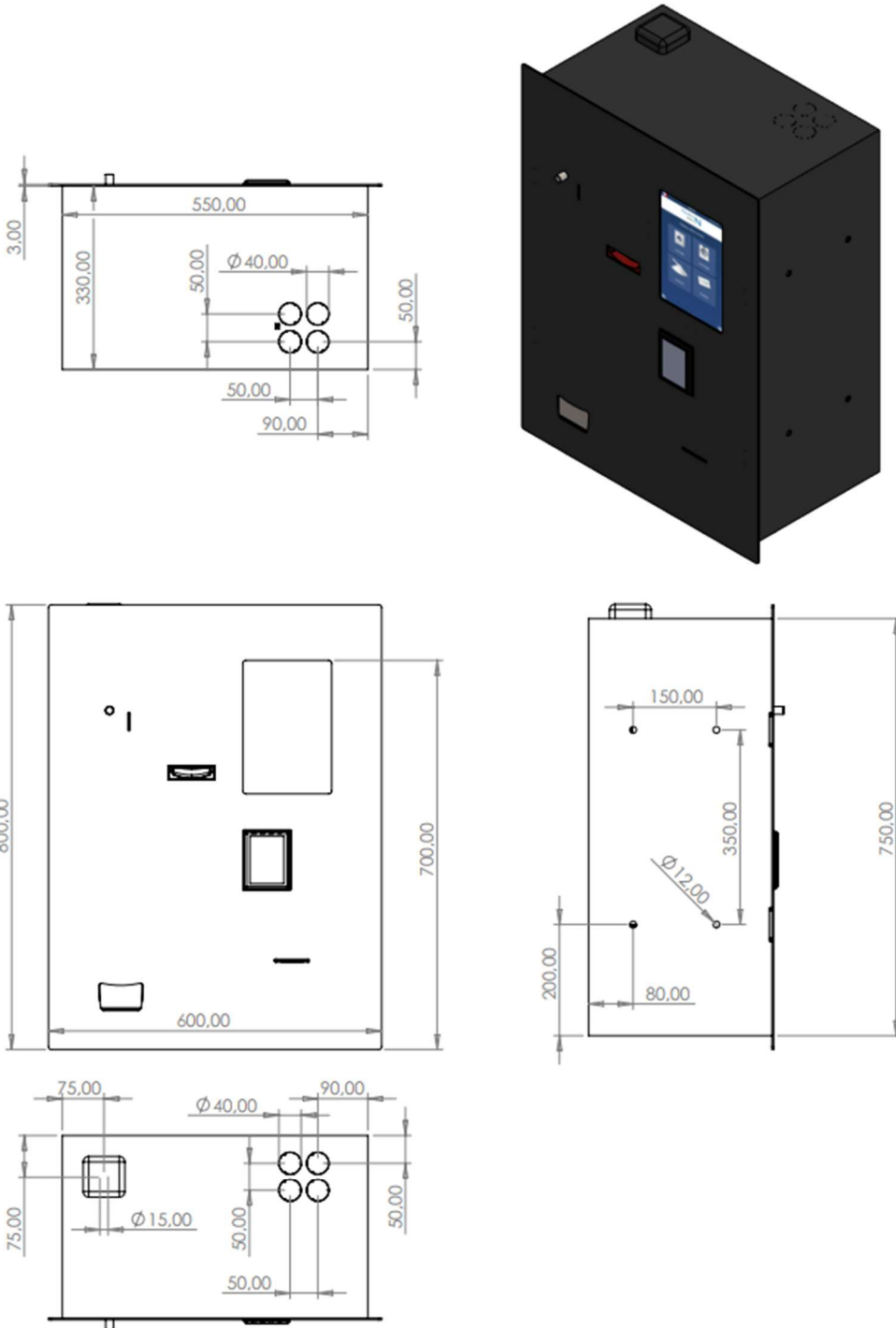

7.5. TNP-M0 Kiosk – Wall Mounted

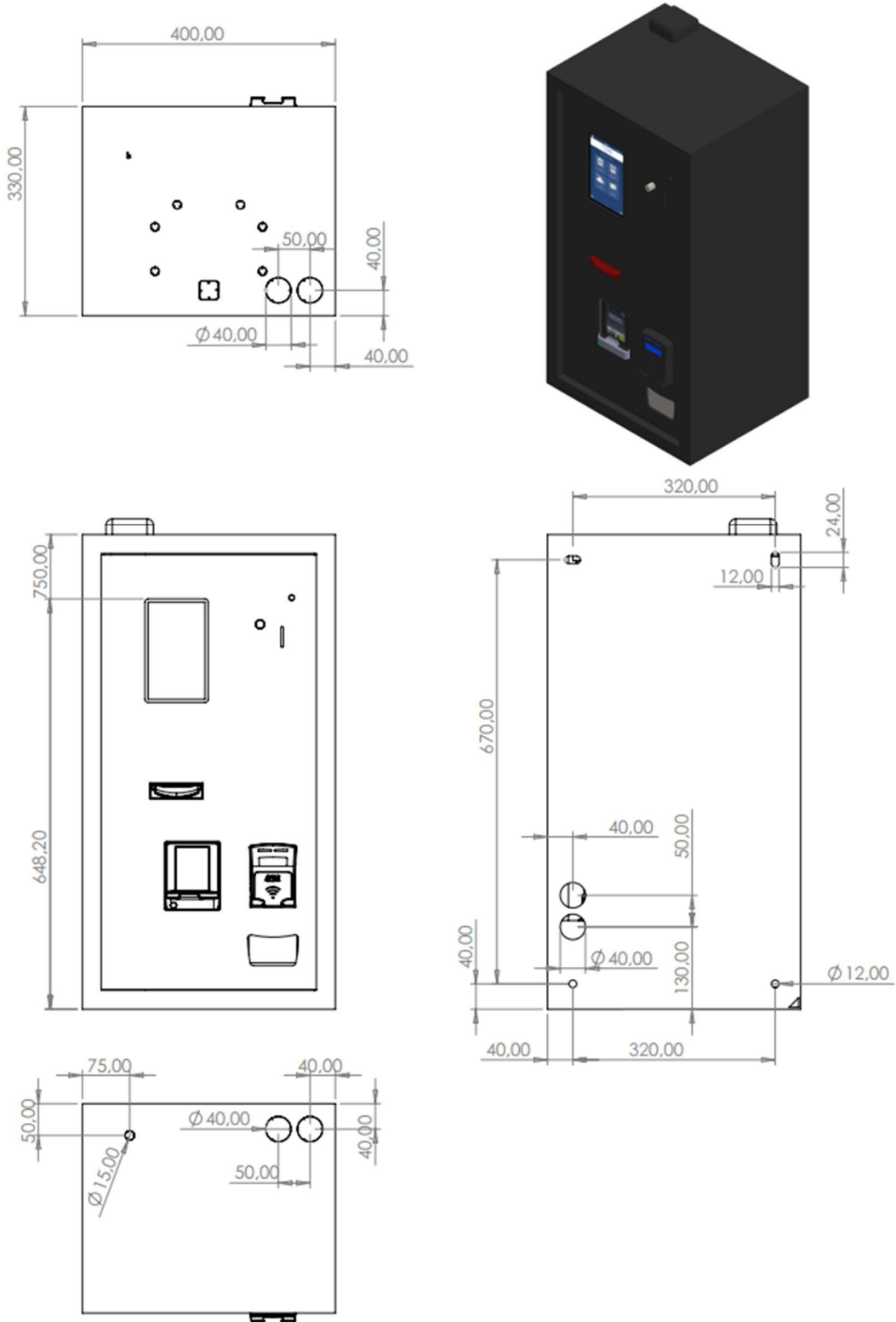

7.6. TNP-M1 Kiosk – Wall-inserted

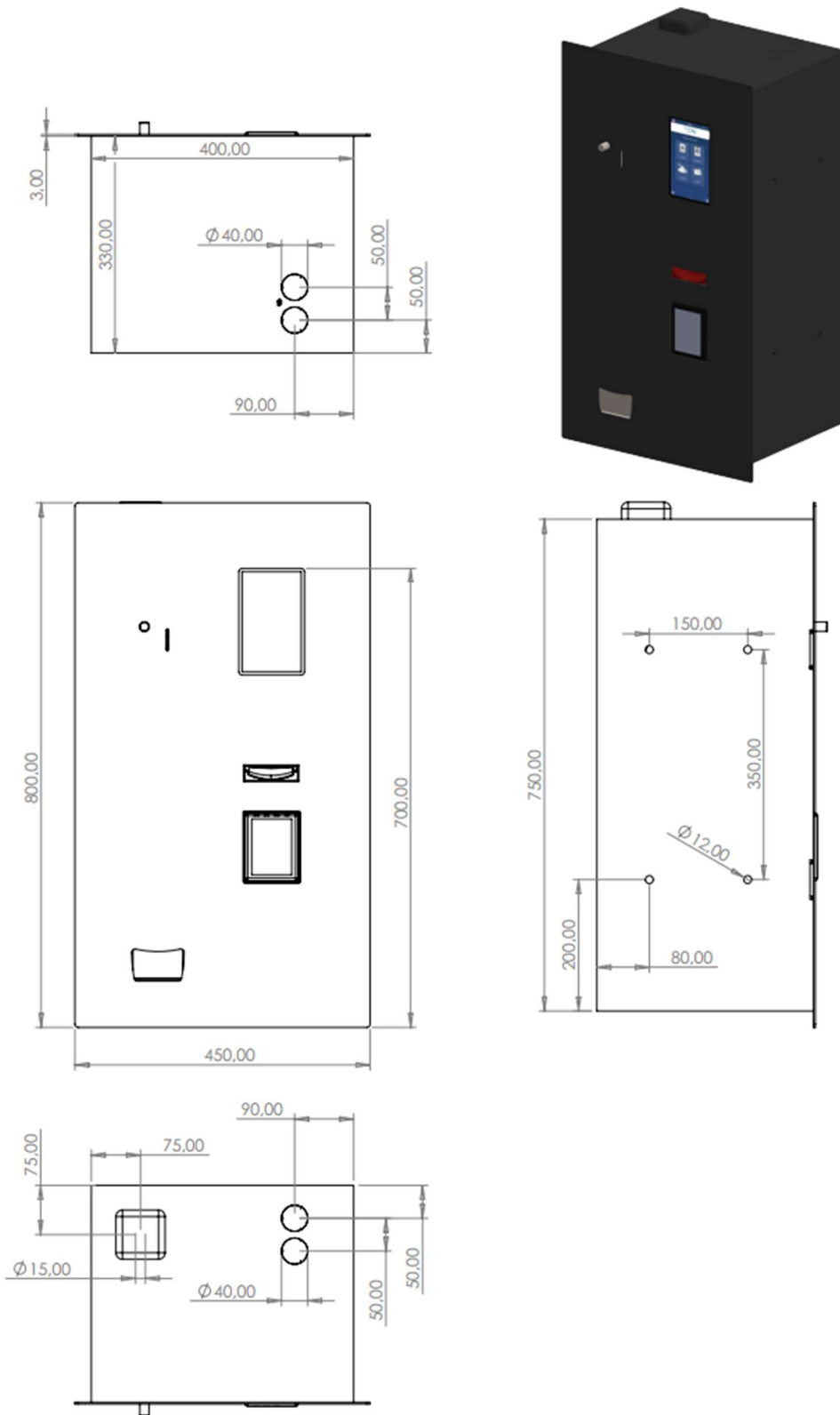

7.7. TNP-P0 Kiosk – Wall Mounted

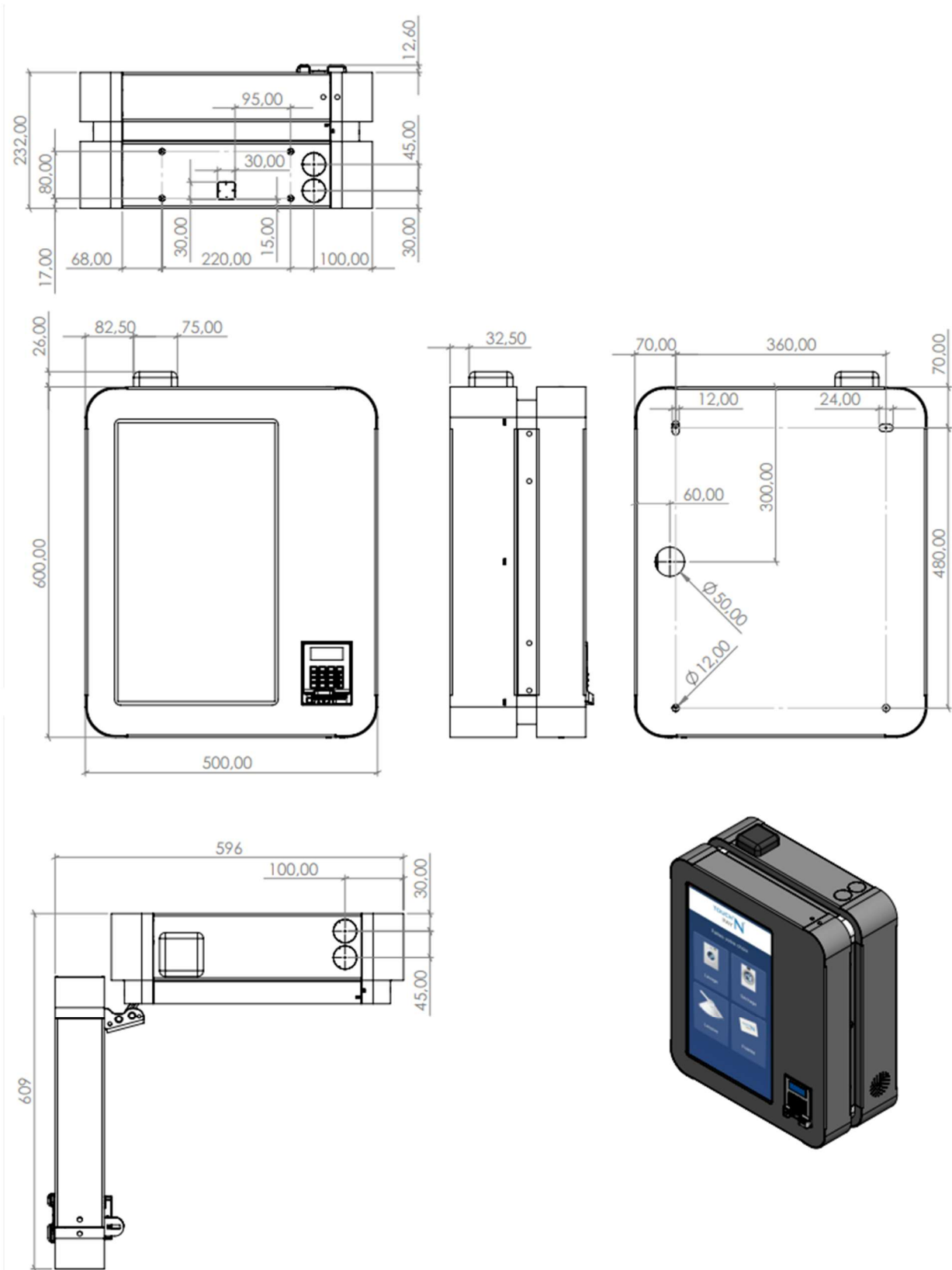

7.8. TNP-P1 Kiosk – Wall-inserted

